



Voyager 4300 UC Series Bluetooth headset User guide

SUMMARY

This guide provides the end-user with task-based user information for the featured product.

Legal information

Copyright and license

© 2026, HP Development Company, L.P. The information contained herein is subject to change without notice. The only warranties for HP products and services are set forth in the express warranty statements accompanying such products and services. Nothing herein should be construed as constituting an additional warranty. HP shall not be liable for technical or editorial errors or omissions contained herein.

Trademark credits

All third-party trademarks are the property of their respective owners. Bluetooth is a trademark owned by its proprietor and used by HP Inc. under license.

Privacy policy

HP complies with applicable data privacy and protection laws and regulations. HP products and services process customer data in a manner consistent with the HP Privacy Policy. Please refer to [HP Privacy Statement](#).

Open source software used in this product

This product contains open source software. You may receive the open source software from HP up to three (3) years after the distribution date of the applicable product or software at a charge not greater than the cost to HP of shipping or distributing the software to you. To receive software information, as well as the open source software code used in this product, contact HP by email at ipgoopensourceinfo@hp.com.

Table of contents

Headset overview	1
Be safe	1
USB Bluetooth adapter LEDs	2
Charge stand	2
Connect and pair	3
Connect to PC	3
Configure USB adapter	3
Pair to mobile device	4
Pair BT700 USB adapter again	4
Pair mode	5
Fit and charge	6
Wear on the right or left	6
Charge	6
Check headset battery status	7
Load software	8
Update your Poly device	8
Basics	9
Power on/off	9
Adjust the volume	9
Adjust headset microphone volume (softphone)	9
Adjust voice prompt volume	9
Make/Take/End Calls	9
Answer or end a call	9
Answer a second call	10
Mute	10
Hold a call	10
Switch between calls (flash)	10
Call back last call (smartphone)	10
Answer calls from a second device	10
Launch Microsoft Teams (Teams model only)	10
Play or pause audio	11
Voice assistant (smartphone feature)	11
More Features	12
Select language	12

Adjust voice prompt volume	12
DeepSleep Mode	12
Online indicator	12
Corded mode (audio over USB)	12
Troubleshooting	13
What's in the box	15
Safety warnings	17
Safety Instructions	17
Support	19

Headset overview

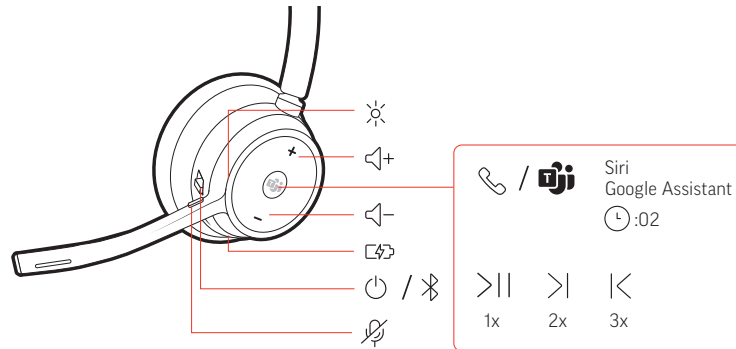

Icon	Description
	LEDs/Online indicator
	Volume up
	Call button/Press to interact with Microsoft Teams (app required)
Siri®, Google Assistant™	Smartphone feature: Default voice assistant
	Play/pause**
	Next track**
	Previous track**
	Volume down
	Charge port
	Power
	Bluetooth® pairing
	Mute/unmute

NOTE: **Functionality varies by application. May not function with web-based apps.

Be safe

Please read the safety guide for important safety and regulatory information before using your new device.

USB Bluetooth adapter LEDs

Your high-fidelity Bluetooth USB adapter comes pre-paired to your Poly device. Plug it into your computer to connect to high-fidelity computer audio.

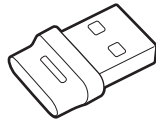

NOTE: Your adapter's USB connection type and design may vary, but the function is the same.

Table 1-1 Standard LEDs

LED behavior	Description
Flashing red and blue	Pairing
Solid blue	Device connected
Flashing blue	On a call
Solid red	Mute active
Flashing purple	Streaming media from computer

Table 1-2 LEDs with Microsoft Teams*

LED behavior	Description
Flashing red and blue	Pairing
Solid purple	Microsoft Teams connected
Flashing blue	On a call
Solid red	Mute active
Pulsing purple	Microsoft Teams notification

*Requires Microsoft Teams desktop application.

Charge stand

Select models only.

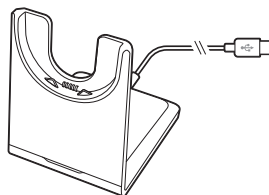

NOTE: The charge stand plugs into a computer or wall charger's USB port.

Connect and pair

Connect to PC

Your Bluetooth USB adapter provides the best connection, softphone functionality and acoustic sound quality through your headset. The adapter comes pre-paired to your headset.

1. Turn on your headset and insert the Bluetooth USB adapter into your laptop or PC.

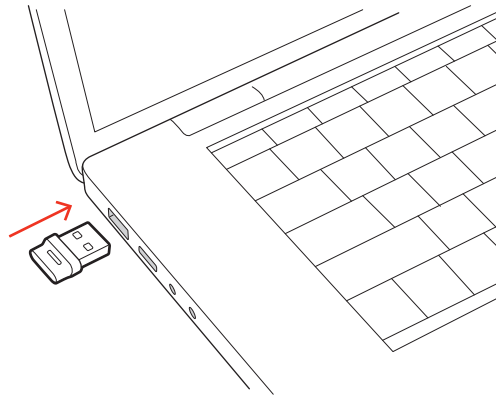

2. The USB adapter LED flashes and then turns solid to indicate the headset is connected to the USB adapter. If you are wearing your headset you hear “PC connected” to indicate the connection has been established. When on a call, the LED on the USB adapter flashes blue. When not on a call the LED is solid.
3. Load HP Poly Studio Desktop by visiting hp.com/studio. This allows you to customize your headset behavior through advanced settings and options.

Configure USB adapter

Your high-fidelity Bluetooth USB adapter comes ready to take calls. If you want to listen to music, you will need to configure your Bluetooth USB adapter.

Windows

1. To configure your Bluetooth USB adapter to play music, go to **Start menu > Control Panel > Sound > Playback tab**. Select **Poly BT700** or **Plantronics BT600**, set it as the Default Device and click OK.
2. To pause music when you place or receive calls, go to **Start menu > Control Panel > Sound > Communications tab** and select the desired parameter.

Mac

- To configure the Bluetooth USB adapter, go to **Apple menu > System Preferences > Sound**. On both the Input and Output tabs, select **Poly BT700** or **Plantronics BT600**.

Pair to mobile device

1. To put your headset in pair mode, slide and hold the Power  switch away from the off position until you hear "pairing" and the headset LEDs flash red and blue.



2. Activate Bluetooth on your phone and set it to search for new devices.

- *iPhone* **Settings > Bluetooth > On***
- *Android* **Settings > Bluetooth On > Scan for devices***

 **NOTE:** *Menus may vary by device.

3. Select "Poly V43XX Series."

Once successfully paired, you hear "pairing successful" and the headset LEDs stop flashing.

 **NOTE:** Your headset can pair with up to 8 devices but only maintain 2 connections simultaneously; this includes the Bluetooth adapter.

Pair BT700 USB adapter again

Typically, your USB Bluetooth adapter is pre-paired to your Poly audio device. In the event that your adapter is disconnected or bought separately, you will need to pair the adapter to your Poly device.

Your USB adapter requires HP Poly Studio Desktop to pair to a Poly audio device. Download: hp.com/studio.

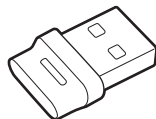

 **NOTE:** Adapter design varies by USB connection.

1. Insert the high-fidelity Bluetooth USB adapter into your laptop or computer and wait for your computer to recognize it.

2. Put your Poly audio device in pair mode.
3. Launch HP Poly Studio Desktop and navigate to Poly BT700.
4. Put your Bluetooth USB adapter into pair mode by selecting "Pair new device" on the adapter's main page or overflow menu. Your adapter flashes red and blue.

Pairing is successful when you hear "pairing successful" and "PC connected" and the Bluetooth USB adapter LED is solid.

Pair mode

Put your headset in pair mode to connect to a new device or to pair again.

- Slide and hold the headset Power  switch away from the off position until the LEDs flash red and blue.



Fit and charge

Wear on the right or left

- To position the microphone on the right or left side, rotate the microphone boom up and over. Gently bend the boom so it is approximately 2 finger widths from the corner of your mouth.

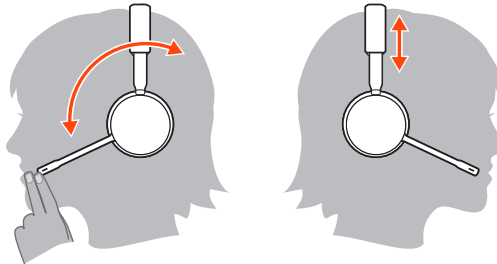

Charge

- Charge your headset using the USB cable or the charge stand (select models only). The headset LEDs flash when charging. It takes approximately 90 minutes to fully charge your headset. The LEDs turn off once charging is complete.



NOTE: The USB cable and charge stand (select models only) plug into a computer or wall charger's USB port.

Figure 3-1 USB cable



Figure 3-2 Charge stand (select models only)

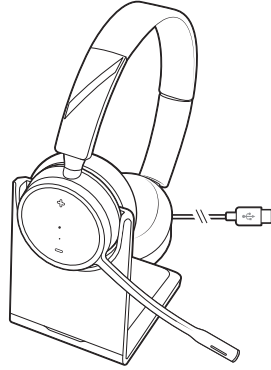

Headset LEDs	What they mean
Off	Charging complete
● ● ●	Battery high
● ●	Battery medium
●	Battery low
⚡	Battery critical

Check headset battery status

Check your headset battery status:



- View status in HP Poly Studio Desktop
- With headset inactive, slide and release the Power  switch away from the off position. Listen to the voice alert or observe the headset LEDs.

Table 3-1 Headset LED behavior while charging

LED	Battery status
Off	Charging complete
● ● ●	Battery high
● ●	Battery medium
●	Battery low
⚡	Battery critical

 **TIP:** To reset the accuracy of the talk time alert, deplete the headset battery then charge fully.

Load software

Download HP Poly Studio to get the most out of your device. Some softphones require the installation of HP software to enable device call control (answer or end a call and mute) functionality.



NOTE: Administrative privileges may be required to download the desktop application. If you don't have administrator privileges on your system, contact your system administrator.

- Download the HP Poly Studio Desktop app at hp.com/studio.
- Download the HP Poly Studio Mobile app at hp.com/studio, the App Store, or Google Play.



Table 4-1 Supported features

Feature	HP Poly Studio Mobile app	HP Poly Studio Desktop app
Configure call control for softphones	Available for some softphones	√
Change headset language	√	√
Enable features	√	√
Choose preferred Equalizer setting	√	√
Battery meter	√	√
Update device firmware	√	√
Manage notifications and alerts	√	√
Schedule wellbeing reminders		√
View user guide	√	√
FindMyHeadset	√	

Update your Poly device

Keep your firmware and software up-to-date to improve performance and add new features to your Poly device.

Update your device using HP Poly Studio. Download at hp.com/studio.

Basics

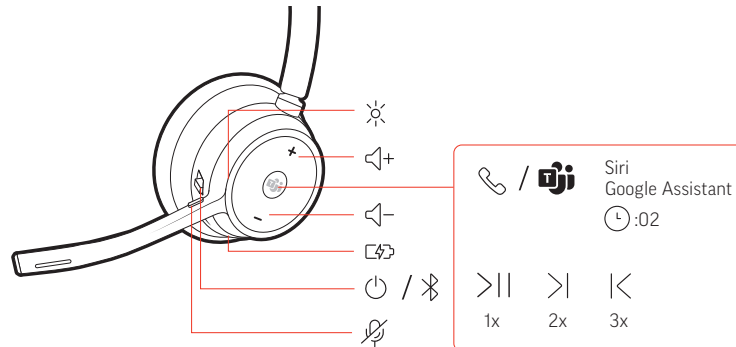

Power on/off

- Slide the Power  switch to power on the headset.

Adjust the volume

- Tap the Volume up (+) or down (-) button.

Adjust headset microphone volume (softphone)

- Place a test softphone call and adjust softphone volume and PC sound volume accordingly.

Adjust voice prompt volume

- Adjust the volume of voice alerts and prompts in HP Poly Studio **Settings** > **Ringtones & Volume**. Download the app: hp.com/studio



Make/Take/End Calls

Answer or end a call

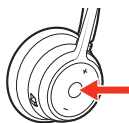
- Tap the Call  button.



Answer a second call

- First, tap the Call button  to end current call, then tap the Call button  again to answer new call.

Mute

- During an active call, press the Mute  button to mute or unmute your headset.

Hold a call

- To hold an active call, press the headset Call button for 2 seconds. Press the Call button to resume a held call.

Switch between calls (flash)

- To switch between calls, press the headset Call button for 2 seconds.



NOTE: Available for softphone calls only. Does not work with mobile calls.

Call back last call (smartphone)

- To dial your last number you dialed, double-tap the Call button.

Answer calls from a second device

It's easy to answer calls from two devices (including softphone).

When on a call, you hear a ringtone notification of the incoming call from the second paired device.

- To answer a second call from the other device, first tap the Call  button to end the current call and tap the Call button again to answer the new call. If you choose to not answer the second call, it will go to voicemail.

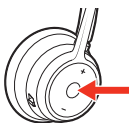

Launch Microsoft Teams (Teams model only)

Tap your headset Teams button to quickly open and use the Microsoft Teams desktop app.

- When not on a call, tap your Teams  button to view Microsoft Teams app on your computer.

- When your connected USB adapter LED pulses purple, tap your Teams button to view Teams notifications.



NOTE: Teams model and Teams desktop application required. Teams mobile application is not supported.

Play or pause audio

- Tap the Call  button to pause or resume streaming audio.



NOTE: Functionality varies by application. May not function with web-based apps.

Voice assistant (smartphone feature)

- **Siri, Google Assistant, Cortana** Press and hold the Call button for 2 seconds to activate your phone's default voice assistant. Wait for the phone prompt to activate voice dialing, search, and other smartphone voice controls.

More Features

Select language

- You can wirelessly change your headset language using HP Poly Studio. Download: hp.com/studio.

Adjust voice prompt volume

- Adjust the volume of voice alerts and prompts in HP Poly Studio **Settings > Ringtones & Volume**. Download the app: hp.com/studio

DeepSleep Mode

If you leave your headphones powered on but out of range of your paired phone or USB adapter for more than 7 days, your headset conserves its battery power by entering into DeepSleep mode.

- Once back in range with your phone or USB adapter, press the Call control button to exit DeepSleep mode.

Online indicator

- Your headset LED illuminates red to inform others that you are on a call. Manage settings in HP Poly Studio.

Corded mode (audio over USB)

If your audio is cutting out during softphone calls, you may be experiencing Bluetooth density problems. Improve audio performance by using density-friendly corded mode.

1. Disconnect your Bluetooth USB adapter from your computer
2. Connect your headset directly to your computer with the provided 1.5 m USB cable
3. Power off your headset to use density-friendly corded mode



NOTE: Your headset battery charges while in corded mode.

Troubleshooting

Find solutions to improve your headset experience.

Issue	Solutions
How do I pair my headset to a mobile device?	See Pair to mobile device on page 4 .
How do I pair my headset to a computer or laptop?	Plug in the USB Bluetooth adapter to your computer or laptop. The adapter is paired to your headset and connects to computer audio. See Connect to PC on page 3 .
Why should I use the USB Bluetooth adapter instead of my computer's Bluetooth?	Your USB Bluetooth adapter provides the best connection, softphone functionality and acoustic sound quality through your headset. See Connect to PC on page 3 , Configure USB adapter on page 3 .
How do I pair my USB Bluetooth adapter to another supported Poly audio device?	HP Poly Studio Desktop is required to pair your USB Bluetooth adapter to another device. Your Bluetooth adapter remembers up to 2 supported Poly audio devices, but connects to only one at a time. See Pair USB adapter again on page 4 .
Can I connect my headset to a mobile phone and computer at the same time?	Yes, your headset can connect to mobile and PC. Your headset remembers up to 8 devices, but connect to up to 2 devices at a time. That includes the USB Bluetooth adapter.
The headset audio is not working as expected when connected to my computer. <ul style="list-style-type: none">• During a call, nobody can hear me• During a call, I can't hear anybody• Music is not coming through my headset• When I play music and a call comes in, the music is too loud or doesn't pause	Check the following: <ul style="list-style-type: none">• To configure the headset sound on your computer, see Configure USB adapter on page 3.• Ensure that only one softphone application is opened at a time.• For best performance, ensure your headset firmware is up-to-date. See Update your Poly device on page 8.
My headset call control is not working as expected when on a softphone call.	Check the following: <ul style="list-style-type: none">• For best performance, ensure your headset firmware is up-to-date. See Update your Poly device on page 8.• Ensure that only one softphone application is opened at a time.• If required to enable headset control (answer/end and mute) functionality, ensure you have HP Poly Studio Desktop installed. See Load software on page 8.• Select your softphone application in HP Poly Studio Desktop.

Issue	Solutions
How do I interact with Microsoft Teams or Skype for Business?	<ul style="list-style-type: none"> For Microsoft Teams, tap the Call  button to interact. For Skype for Business, press and hold the Call  button for 2 seconds to interact. Set your target phone by going to HP Poly Studio Desktop > Softphones > Software Settings > Target Softphone
Does my Microsoft Teams-enabled headset work with other softphones?	<p>Yes, while your headset is optimized for Microsoft Teams, it can be configured to use with other supported softphones. Set your target phone by going to HP Poly Studio Desktop ></p> <p>Softphones > Software Settings > Target Softphone</p> <p>When you configure another softphone, the Call button:</p> <ul style="list-style-type: none"> doesn't interact with Teams doesn't go to Teams notifications will not launch Cortana
I want to customize my headset features.	<p>Customize your device settings with HP Poly Studio. Download: hp.com/studio</p>
I can't activate Amazon Alexa on my headset.	<ul style="list-style-type: none"> Alexa requires one-time setup in HP Poly Studio Mobile for iOS/Android. See Enable and use Amazon Alexa on page 11.
The headset audio is cutting out during softphone calls.	<p>You may be experiencing Bluetooth density issues. Use density-friendly corded mode. See Corded mode (audio over USB) on page 12.</p>
I want to use my headset as a USB corded headset with my computer.	<p>Your headset can be used in corded mode. See Corded mode (audio over USB) on page 12.</p>
Can I use my headset while charging it?	<p>Your headset charges while in corded mode. See Corded mode (audio over USB) on page 12.</p>
The headset talk time is not accurate.	<p>Deplete your headset battery and then fully charge to reset the accuracy of the talk time prompts.</p>
I don't have enough charge ports for my Bluetooth USB adapter and my optional charge stand.	<p>Try the following:</p> <ul style="list-style-type: none"> Plug your charge stand into a wall charger To charge your headset while connected to your computer, use corded mode. See Corded mode (audio over USB) on page 12.

What's in the box

Contents may vary by model.

Figure 8-1 Stereo or mono headset



Figure 8-2 Bluetooth USB adapter (USB-A or USB-C, design varies)

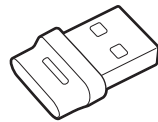

Figure 8-3 Charge stand (select models only)

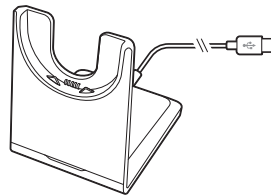

Figure 8-4 Headset carrying case

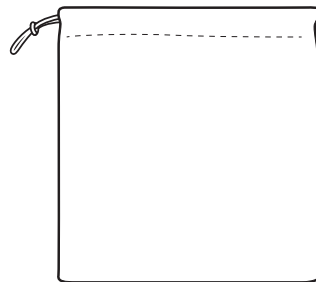

Figure 8-5 USB-A to USB-C cable

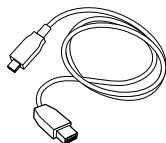
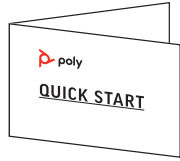

Figure 8-6 Quick start guide



Safety warnings

Safety Instructions

To reduce the risk of fire, electric shock, injury to persons and damage to property, read all operating instructions and the following safety instructions before using your HP product. Operating, storage and charging temperature is 10°C to 40°C (50°F to 104°F).

- Only use those HP products and accessories designed for use with this product.
- If you experience a skin irritation after using this product, discontinue use and contact HP.
- CHILDREN. Never allow children to play with the product-small parts may be a choking hazard.
- Do not disassemble the product as this may expose you to dangerous voltages or other risks. Incorrect reassembly can cause electric shock or fire when the product is subsequently used.
- Unplug, discontinue use and contact HP if the product overheats or has a damaged outer casing, cord or plug.
- Exposure to high volume sound levels or excessive sound pressure may cause temporary or permanent damage to your hearing. Although there is no single volume setting that is appropriate for everyone, you should always use your headset/headphones with the volume set at moderate levels and avoid prolonged exposure to high volume sound levels. The louder the volume, the less time is required before your hearing could be affected. You may experience different sound levels when using your headset/headphones with different devices. The device you use and its settings affect the level of sound you hear. If you experience hearing discomfort, you should stop listening to the device through your headset/headphones and have your hearing checked by your doctor. To protect your hearing, some hearing experts suggest that you:
 1. Set the volume control in a low position before putting your headset/headphones on your ears and use as low a volume as possible.
 2. Avoid turning up the volume to block out noisy surroundings. Whenever possible, use your headset/headphones in a quiet environment with low background noise.
 3. Limit the amount of time you use headsets/headphones at high volume levels.
 4. Turn the volume down if the sound from the headset/headphones prevent you from hearing people speaking near you.

- If you use your headset/headphones while driving, check local laws regarding use of a mobile phone and headset, and ensure your attention and focus remain on driving safely. Use of a headset/headphones that covers both ears will impair your ability to hear other sounds and in most regions is illegal to use while operating a motor vehicle or riding a bicycle and may be a serious hazard for you and others.
- If this product includes earbuds/eartips, install and use them in accordance with the instructions provided. Do not force earbuds/eartips down the ear canal. Consult a doctor if they become lodged in the ear canal.
- Plug the mains adapter or charger into a socket-outlet that is near to the equipment and will be easily accessible.

Battery Warnings for Wireless Products

- If your product has an embedded, non-replaceable battery, do not attempt to open the product or remove the battery as this may cause injury and/or damage the product. If your product has a replaceable battery, use only the battery type supplied by HP. Remove a spent battery promptly.
- Replace rechargeable batteries after three years or 300 charge cycles, whichever occurs first.
- Do not dispose of the product or battery in a fire or heat above 40°C (104°F).
- Do not expose the battery to extremely high temperatures. It may result in an explosion or the leakage of flammable liquid or gas.
- Do not open, deform or mutilate the battery. There may be corrosive materials which can cause damage to eyes or skin and may be toxic if swallowed.
- Never put batteries in mouth. If swallowed, contact a physician or poison control center.
- Swallowing may lead to burns, perforation of soft tissue, and death. Severe burns can occur within 2 hours of ingestion.
- Always store batteries where children cannot reach them.
- Do not allow any battery or its holder to contact metal objects such as keys or coins.
- RECYCLING: The product battery must be recycled or disposed of properly. Contact your local recycling center for battery removal and proper disposal.
- Use only the charger supplied by HP to charge the product and follow the charging instructions provided. Alternatively, if your headset is designed to be charged with your cell phone charger, use only cell phone chargers approved and provided by your cell phone manufacturer. Do not use the charger for any other purpose. Ensure that the voltage rating corresponds to the power supply you intend to use.

Support

NEED MORE HELP?

support.hp.com/poly

HP Inc.

1501 Page Mill Road
Palo Alto, CA 94304, U.S.A.
650-857-1501

HP REG 23010, 08028

Barcelona, Spain

HP Inc UK Ltd

Regulatory Enquiries, Earley West
300 Thames Valley Park Drive
Reading, RG6 1PT
United Kingdom

台灣惠普資訊科技股份有限公司

臺北市南港區經貿二路 66 號 10 樓
電話: 02-37899900

RMN (Regulatory Model Number): V4310, V4320, BT700, BT700C