



# Maintenance and Service Guide

## SUMMARY

This guide provides information about spare parts, removal and replacement of parts, security, backing up, and more.

## Legal information

© Copyright 2021 HP Development Company, L.P.

AMD, Ryzen, and Radeon are trademarks of Advanced Micro Devices, Inc. Bluetooth is a trademark owned by its proprietor and used by HP Inc. under license. Google Chrome is a trademark of Google LLC. Intel, vPro, and XMM are trademarks of Intel Corporation or its subsidiaries in the U.S. and/or other countries. Microsoft and Windows are either registered trademarks or trademarks of Microsoft Corporation in the United States and/or other countries. USB Type-C and USB-C are registered trademarks of USB Implementers Forum. DisplayPort™ and the DisplayPort™ logo are trademarks owned by the Video Electronics Standards Association (VESA®) in the United States and other countries. Miracast is a registered trademark of Wi-Fi Alliance.

The information contained herein is subject to change without notice. The only warranties for HP products and services are set forth in the express warranty statements accompanying such products and services. Nothing herein should be construed as constituting an additional warranty. HP shall not be liable for technical or editorial errors or omissions contained herein.

First Edition: April 2021

Document Part Number: M74088-001

### Product notice

This guide describes features that are common to most models. Some features may not be available on your computer.

Not all features are available in all editions or versions of Windows. Systems may require upgraded and/or separately purchased hardware, drivers, software or BIOS update to take full advantage of Windows functionality. Windows 10 is automatically updated, which is always enabled. ISP fees may apply and additional requirements may apply over time for updates. Go to <http://www.microsoft.com> for details.

To access the latest user guides, go to <http://www.hp.com/support>, and follow the instructions to find your product. Then select **Manuals**.

### Software terms

By installing, copying, downloading, or otherwise using any software product preinstalled on this computer, you agree to be bound by the terms of the HP End User License Agreement (EULA). If you do not accept these license terms, your sole remedy is to return the entire unused product (hardware and software) within 14 days for a full refund subject to the refund policy of your seller.

For any further information or to request a full refund of the price of the computer, please contact your seller.

## Important notice about Customer Self-Repair parts

Your computer includes Customer Self-Repair parts and parts that should be accessed by only an authorized service provider.



**IMPORTANT:** See "Removal and replacement procedures for Customer Self-Repair parts" for details.

Accessing parts described in "Removal and replacement procedures for authorized service provider parts" can damage the computer or void your warranty.

---

## Safety warning notice

Reduce the possibility of heat-related injuries or of overheating the computer by following the practices described.

- 
- ⚠ WARNING!** To reduce the possibility of heat-related injuries or of overheating the computer, do not place the computer directly on your lap or obstruct the computer air vents. Use the computer only on a hard, flat surface. Do not allow another hard surface, such as an adjoining optional printer, or a soft surface, such as pillows or rugs or clothing, to block airflow. Also, do not allow the AC adapter to come into contact with the skin or a soft surface, such as pillows or rugs or clothing, during operation. The computer and the AC adapter comply with the user-accessible surface temperature limits defined by applicable safety standards.
-

---

# Table of contents

<b>1 Product description</b> .....	<b>1</b>
<b>2 Components</b> .....	<b>5</b>
Right .....	5
Left .....	6
Display .....	7
Keyboard area .....	8
Touchpad .....	8
Touchpad settings .....	8
Adjusting touchpad settings .....	8
Turning on the touchpad .....	8
Touchpad components .....	8
Lights .....	9
Button, speakers, and fingerprint reader .....	10
Special keys .....	12
Bottom .....	13
Labels .....	13
Using a SIM card (select products only) .....	15
Determining the correct SIM card size for your computer .....	15
Inserting a SIM card in an external slot .....	15
<b>3 Illustrated parts catalog</b> .....	<b>17</b>
Computer major components .....	17
Display assembly subcomponents .....	23
Cable Kit .....	25
Plastics Kit .....	26
Miscellaneous parts .....	26
<b>4 Removal and replacement procedures preliminary requirements</b> .....	<b>29</b>
Tools required .....	29
Service considerations .....	29
Plastic parts .....	29
Cables and connectors .....	29
Drive handling .....	30
Electrostatic discharge information .....	30
Generating static electricity .....	30
Preventing electrostatic damage to equipment .....	31
Personal grounding methods and equipment .....	31
Grounding the work area .....	32
Recommended materials and equipment .....	32
Packaging and transporting guidelines .....	33
<b>5 Removal and replacement procedures for Customer Self-Repair parts</b> .....	<b>35</b>
Component replacement procedures .....	35
Preparation for disassembly .....	35
Bottom cover .....	35

Memory modules .....	37
Solid-state drive .....	40
<b>6 Removal and replacement procedures for authorized service provider parts .....</b>	<b>43</b>
Component replacement procedures .....	43
Preparation for disassembly .....	43
Battery .....	43
WLAN module .....	45
WWAN module .....	46
RTC battery .....	48
Speakers .....	49
Power connector cable .....	50
USB board .....	51
Fingerprint reader board .....	52
Touchpad .....	53
Fan .....	54
Heat sink .....	55
System board .....	56
Display assembly .....	60
Keyboard with top cover .....	74
<b>7 Backing up, restoring, and recovering .....</b>	<b>77</b>
Backing up information and creating recovery media .....	77
Using Windows tools for backing up .....	77
Using the HP Cloud Recovery Download Tool to create recovery media (select products only) .....	77
Restoring and recovering your system .....	78
Creating a system restore .....	78
Restoring and recovery methods .....	78
Recovering using HP Recovery media .....	78
Changing the computer boot order .....	79
Using HP Sure Recover (select products only) .....	79
<b>8 Using HP PC Hardware Diagnostics .....</b>	<b>81</b>
Using HP PC Hardware Diagnostics Windows (select products only) .....	81
Using an HP PC Hardware Diagnostics Windows hardware failure ID code .....	81
Accessing HP PC Hardware Diagnostics Windows .....	81
Accessing HP PC Hardware Diagnostics Windows from HP Help and Support (select products only) .....	81
Accessing HP PC Hardware Diagnostics Windows from Support Assistant .....	82
Accessing HP PC Hardware Diagnostics Windows from the Start menu (select products only) .....	82
Downloading HP PC Hardware Diagnostics Windows .....	82
Downloading the latest HP PC Hardware Diagnostics Windows version from HP .....	82
Downloading the HP PC Hardware Diagnostics Windows from the Microsoft Store .....	83
Downloading HP Hardware Diagnostics Windows by product name or number (select products only) .....	83
Installing HP PC Hardware Diagnostics Windows .....	83
Using HP PC Hardware Diagnostics UEFI .....	83
Using an HP PC Hardware Diagnostics UEFI hardware failure ID code .....	83
Starting HP PC Hardware Diagnostics UEFI .....	84
Downloading HP PC Hardware Diagnostics UEFI to a USB flash drive .....	84
Downloading the latest HP PC Hardware Diagnostics UEFI version .....	84
Downloading HP PC Hardware Diagnostics UEFI by product name or number (select products only) .....	85
Using Remote HP PC Hardware Diagnostics UEFI settings (select products only) .....	85
Downloading Remote HP PC Hardware Diagnostics UEFI .....	85
Downloading the latest Remote HP PC Hardware Diagnostics UEFI version .....	85
Downloading Remote HP PC Hardware Diagnostics UEFI by product name or number .....	85
Customizing Remote HP PC Hardware Diagnostics UEFI settings .....	85
<b>9 Computer Setup (BIOS), TPM, and HP Sure Start .....</b>	<b>87</b>
Using Computer Setup .....	87
Navigating and selecting in Computer Setup .....	87

Restoring factory settings in Computer Setup .....	88
Updating the BIOS .....	88
Determining the BIOS version .....	88
Preparing for a BIOS update .....	88
Downloading a BIOS update .....	89
Installing a BIOS update.....	89
Changing the boot order using the f9 prompt .....	89
TPM BIOS settings (select products only) .....	90
Using HP Sure Start (select products only) .....	90
<b>10 Specifications .....</b>	<b>91</b>
Computer specifications.....	91
33.8 cm (13.3 in) display specifications.....	92
Solid-state drive specifications .....	92
Solid-state drive specifications (SATA-3).....	93
<b>11 Statement of memory volatility.....</b>	<b>95</b>
Current BIOS steps .....	95
Nonvolatile memory usage .....	97
Questions and answers.....	99
Using HP Sure Start (select products only) .....	101
<b>12 Power cord set requirements .....</b>	<b>103</b>
Requirements for all countries.....	103
Requirements for specific countries and regions.....	103
<b>13 Recycling.....</b>	<b>107</b>
<b>Index.....</b>	<b>109</b>



# 1

## Product description

This table provides detailed product information.

**Table 1-1 Product components and their descriptions**

Category	Description
<b>Product Name</b>	HP ProBook 635 Aero G8 Notebook PC
<b>Processors</b>	<ul style="list-style-type: none"> <li>• AMD Ryzen™ 7 PRO 5850U with Radeon™ Graphics (1.9 GHz [turbo up to 4.4 GHz], 8 cores, 16 MB L3 cache, 25 W)</li> <li>• AMD Ryzen 7 PRO 5800U with Radeon Graphics (1.9 GHz [turbo up to 4.4 GHz], 8 cores, 16 MB L3 cache, 25 W)</li> <li>• AMD Ryzen 7 5650U with Radeon Graphics (2.3 GHz [turbo up to 4.2 GHz], 6 cores, 16 MB L3 cache, 25 W)</li> <li>• AMD Ryzen 7 5600U with Radeon Graphics (2.3 GHz [turbo up to 4.2 GHz], 6 cores, 16 MB L3 cache, 25 W)</li> <li>• AMD Ryzen 3 5400U with Radeon Graphics (2.6 GHz [turbo up to 4.0 GHz], 4 cores, 8 MB L3 cache, 25 W)</li> </ul>
<b>Chipset</b>	AMD integrated soldered on circuit (SoC)
<b>Display</b>	<ul style="list-style-type: none"> <li>• 33.8 cm (13.3 in), liquid crystal display (LCD), full high-definition (FHD) (1920×1080), antiglare, white light-emitting diode (WLED), ultrawide viewing angle (UWVA), 45% CG, embedded DisplayPort (eDP), bent display panel; typical brightness: 250 nits</li> <li>• 33.8 cm (13.3 in), LCD, FHD (1920×1080), antiglare, WLED, UWVA, 45% CG, eDP for HD webcam, bent display panel; typical brightness: 250 nits</li> <li>• 33.8 cm (13.3 in), LCD, FHD (1920×1080), antiglare, WLED, UWVA, 45% CG, eDP for HD+IR webcam, bent display panel; typical brightness: 250 nits</li> <li>• 33.8 cm (13.3 in), LCD, FHD (1920×1080), antiglare, WLED, UWVA, 100% CG, sRGB, eDP+panel self refresh (PSR) for HD+IR LPALS webcam, bent display panel; typical brightness: 400 nits</li> <li>• 33.8 cm (13.3 in), LCD, FHD (1920×1080), antiglare, WLED, UWVA, 100% CG, sRGB, eDP+panel self refresh (PSR) for HD+IR LPALS webcam, bent display panel, with WWAN antenna; typical brightness: 400 nits</li> <li>• 33.8 cm (13.3 in), LCD, FHD (1920×1080), antiglare, WLED, UWVA, 72% CG, sRGB, eDP+panel self refresh (PSR) for HD+IR SVRALS webcam, bent display panel, with WWAN antenna; typical brightness: 1000 nits</li> <li>• 33.8 cm (13.3 in), LCD, FHD (1920×1080), antiglare, WLED, UWVA, 72% CG, sRGB, eDP+panel self refresh (PSR) for HD+IR SVRALS webcam, bent display panel; typical brightness: 1000 nits</li> </ul>
<b>Memory</b>	<p>Two accessible (by IT or self-maintainers) memory module slots supporting up to 48 GB of RAM</p> <p>DDR4-3200 dual-channel support</p> <p>Supports the following configurations:</p> <ul style="list-style-type: none"> <li>• 48 GB (32 + 16)</li> <li>• 32 GB (32 × 1) or (16 × 2)</li> <li>• 24 GB (16 + 8)</li> <li>• 20 GB (16 + 4)</li> <li>• 16 GB (8 × 2) or (16 × 1)</li> <li>• 12 GB (8 + 4)</li> <li>• 8 GB (8 × 1 or 4 × 2)</li> <li>• 4 GB (4 × 1)</li> </ul>
<b>Primary storage</b>	<b>M.2 2280 solid-state drives (NGFF)</b>

**Table 1-1 Product components and their descriptions (continued)**

Category	Description
	<ul style="list-style-type: none"> <li>• 1 TB, PCIe, Gen3 × 4, SS, TLC</li> </ul>
	<ul style="list-style-type: none"> <li>• 512 GB, PCIe, TLC</li> </ul>
	<ul style="list-style-type: none"> <li>• 512 GB, PCIe, value</li> </ul>
	<ul style="list-style-type: none"> <li>• 256 GB, PCIe, TLC</li> </ul>
	<ul style="list-style-type: none"> <li>• 256, PCIe, value</li> </ul>
	<ul style="list-style-type: none"> <li>• 128 GB, M.2 2280, PCIe-3×2, TLC</li> </ul>
<b>Audio and video</b>	<p>HP Audio</p> <p>Stereo speakers (2), 25 mm × 9 mm × 3 mm, single magnet</p> <p>Microphone (dual array)</p> <p>Camera, HD RGB 720p</p> <p>Camera, HD RGB 720p + IR (infrared)</p> <p>Camera privacy cover</p> <p>Supports WFoV (Wide Field of View)</p> <p>Supports WDR (Wide Dynamic Range)</p> <p>Supports HP Noise Reduction Software</p> <p>Support for models without a camera</p>
<b>Wireless</b>	<p><b>Wireless Local Area Network (WLAN)</b> (select products only)</p> <p>Realtek RTL8822CE 802.11ac 2 × 2 Wi-Fi + Bluetooth® 5 (MU-MIMO supported)</p> <p>Intel® Wi-Fi 6 AX200 + Bluetooth 5 (non-vPro®) (802.11ax 2 × 2, MU-MIMO, supporting gigabit file transfer speeds)</p> <p>Compatible with Miracast® devices</p> <p>Two WLAN antennas configured at top of panel on models without WWAN; configured at hinge cap on models with WWAN</p> <p>Supports HP Connection Optimizer (with data analytics)</p> <p>Supports Static BIOS SAR for Intel modules and Realtek modules</p> <p>Supports HP Extended Range Wireless LAN</p> <p>Supports HP LAN-Wireless Protection (WLAN/LAN/WWAN switching)</p> <p><b>WWAN</b> (select products only)</p> <p>Intel XMM™ 7360 LTE-Advanced (Cat 9)</p> <p>Two WWAN antennas at top of panel</p> <p>WWAN cards are compatible with a programmable removable eSIM</p> <p>Supports WWAN after market option</p>
<b>Ports</b>	<p>HDMI 2.0</p> <p>Audio-out (headphone)/audio-in (microphone) combo jack</p> <p>USB 3.1 Gen 2 Type-C port</p>

**Table 1-1 Product components and their descriptions (continued)**

Category	Description
	(2) USB 3.1 Gen 1 Type-A ports
	AC Smart Pin adapter plug, 4.5 mm
<b>Sensors</b>	Ambient light sensor (ALS)
	Hall sensor
<b>Keyboard/pointing devices</b>	<b>HP Premium Keyboard</b>
	Backlit, spill resistant, HP Dura Keys
	Backlit, spill resistant, HP Dura Keys, SureView
	Not backlit, spill resistant, HP Dura Keys
<b>Power requirements</b>	<b>Battery</b>
	3 cell, 42 Whr, lithium polymer
	3 cell, 53 Whr, lithium polymer
	HP Long Life
	HP Fast Charge Technology
	<b>Smart AC adapters</b>
	65 W, right angle, 4.5 mm
	65 W, right angle, 4.5 mm, for use in Argentina
	65 W, right angle, 4.5 mm, EM
	65 W, straight, USB Type-C®
	45 W, right angle, 4.5 mm
	45 W, right angle, 4.5 mm, for use in Argentina
	45 W, right angle, 4.5 mm, 2 prong (Japan only)
	45 W, straight, USB Type-C
	<b>Power cord</b>
	3 wire, C5, 1.0 m (3.3 ft), conventional
	2 wire, C7, 1.0 m (3.3 ft), conventional
<b>Security</b>	Trusted Platform Module (TPM) 2.0, Infineon, soldered down
	Touch fingerprint sensor (select products only)
	Nano security lock
	Hardware enforced firmware protection: HP Hardware Root of Trust + Sure Start Gen7
<b>Operating system</b>	Windows® 10 Home 64
	Windows 10 Home 64 Advanced
	Windows 10 Home 64 Advanced Single Language
	Windows 10 Home 64 Chinese Market CPPP
	Windows 10 Home 64 High-End Chinese Market CPPP

**Table 1-1 Product components and their descriptions (continued)**

<b>Category</b>	<b>Description</b>
	Windows 10 Home 64 Plus
	Windows 10 Home 64 Plus Single Language
	Windows 10 Home 64 Plus Single Language Africa Market PPP
	Windows 10 Home 64 Plus Single Language APAC EM PPP
	Windows 10 Home 64 Plus Single Language India Market PPP
	Windows 10 Home 64 Plus Single Language Indonesia Market PPP
	Windows 10 Home 64 Single Language
	Windows 10 Home 64 Single Language Africa Market PPP
	Windows 10 Home 64 Single Language APAC Market PPP
	Windows 10 Home 64 Single Language India Market PPP
	Windows 10 Home 64 Single Language Indonesia Market PPP
	Windows 10 Pro 64
	Windows 10 Pro 64 Chinese Market
	Windows 10 Pro 64 StF MSNA Plus
	Windows 10 Pro 64 StF MSNA Standard
	Windows 10 Pro 64 StF MSNA Strategic
	FreeDOS 3.0
<b>Serviceability</b>	<b>End user replaceable parts</b>
	AC adapter
	Memory module
	Solid-state drive

## 2 Components



Your computer features top-rated components. This chapter provides details about your components, where they are located, and how they work.

### Right

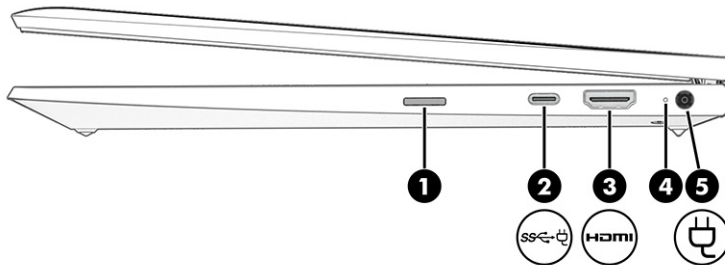
Use the illustration and table to identify the components on the right side of the computer.



**Table 2-1** Right-side components and their descriptions

Component	Description
(1)	SIM card slot (select products only) Supports a wireless subscriber identity module (SIM) card.
(2)	 USB Type-C <sup>®</sup> power connector and SuperSpeed port Connects an AC adapter that has a USB Type-C connector, supplying power to the computer and, if needed, charging the computer battery. – and – Connects a USB device, provides high-speed data transfer, and (for select products) charges small devices when the computer is on or in Sleep mode. – and – Connects a display device that has a USB Type-C connector, providing DisplayPort™ output. <b>NOTE:</b> Cables, adapters, or both (purchased separately) might be required.
(3)	 HDMI port Connects an optional video or audio device, such as a high-definition television, any compatible digital or audio component, or a high-speed High Definition Multimedia Interface (HDMI) device.
(4)	Battery light When AC power is connected:

**Table 2-1** Right-side components and their descriptions (continued)



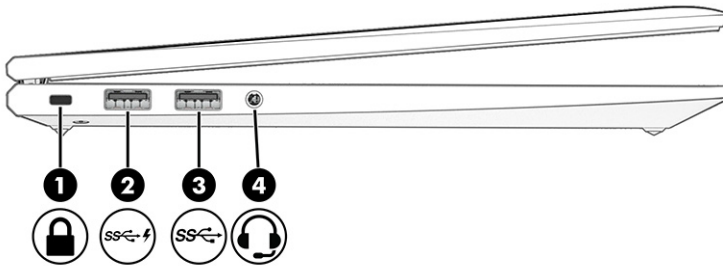

Component	Description
	<ul style="list-style-type: none"> <li>• White: The battery charge is greater than 90 percent.</li> <li>• Amber: The battery charge is from 0 to 90 percent.</li> <li>• Off: The battery is not charging.</li> </ul> <p>When AC power is disconnected (battery not charging):</p> <ul style="list-style-type: none"> <li>• Blinking amber: The battery has reached a low battery level. When the battery has reached a critical battery level, the battery light begins blinking rapidly.</li> <li>• Off: The battery is not charging.</li> </ul>
(5)  Power connector	Connects an AC adapter.

## Left

Use the illustration and table to identify the components on the left side of the computer.



**Table 2-2** Left-side components and their descriptions

Component	Description
(1)  Security cable slot	Attaches an optional security cable to the computer.  <b>NOTE:</b> The security cable is designed to act as a deterrent, but it might not prevent the computer from being mishandled or stolen.
(2)  USB SuperSpeed port with HP Sleep and Charge	Connects a USB device, provides high-speed data transfer, and charges small devices, even when the computer is off.
(3)  USB SuperSpeed port	Connects a USB device, provides high-speed data transfer, and (for select products) charges small devices when the computer is on or in Sleep mode.
(4)  Audio-out (headphone)/Audio-in (microphone) combo jack	Connects optional powered stereo speakers, headphones, earbuds, a headset, or a television audio cable. Also connects an optional headset microphone. This jack does not support optional standalone microphones.

**WARNING!** To reduce the risk of personal injury, adjust the volume before putting on headphones, earbuds, or a headset. For additional safety information, see the *Regulatory, Safety, and Environmental Notices*.

To access this guide:

**Table 2-2** Left-side components and their descriptions (continued)

Component	Description
	<p>▲ Type <b>HP Documentation</b> in the taskbar search box, and then select <b>HP Documentation</b>.</p> <p><b>NOTE:</b> When a device is connected to the jack, the computer speakers are disabled.</p>

## Display

Use the illustration and table to identify the display components.

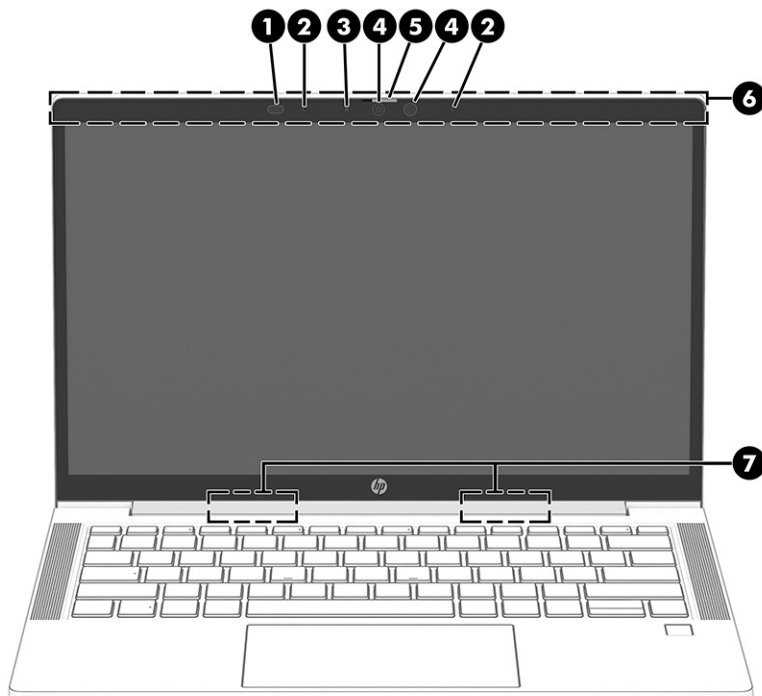

**Table 2-3** Display components and their descriptions

Component	Description
(1) Ambient light sensor (select products only)	Adjusts the brightness of the display, depending on the ambient light.
(2) Internal microphones (2)	Record sound.
(3) Camera light (select products only)	On: One or more cameras are in use.
(4) Camera(s) (select products only)	<p>Allow(s) you to video chat, record video, and record still images. Some cameras also allow a facial recognition logon to Windows, instead of a password logon.</p> <p><b>NOTE:</b> Camera functions vary depending on the camera hardware and software installed on your product.</p>
(5) Camera privacy cover (select products only)	<p>By default, the camera lens is uncovered, but you can slide the camera privacy cover to block the camera's view. To use the camera, slide the camera privacy cover in the opposite direction to reveal the lens.</p> <p><b>NOTE:</b> If you have both front-facing and rear-facing cameras, when one camera lens is revealed and ready to use, the other is concealed.</p>

**Table 2-3 Display components and their descriptions (continued)**

Component	Description
(6) WLAN or WWAN antennas* (select products only)	Send and receive wireless signals to communicate with wireless local area networks (WLANs) or wireless wide area networks (WWANs).
(7) WLAN antennas* (select products only)	Send and receive wireless signals to communicate with wireless local area networks (WLANs).

\*The antennas are not visible from the outside of the computer. For optimal transmission, keep the areas immediately around the antennas free from obstructions.

For wireless regulatory notices, see the section of the *Regulatory, Safety, and Environmental Notices* that applies to your country or region.

To access this guide:

▲ Type `HP Documentation` in the taskbar search box, and then select **HP Documentation**.

## Keyboard area

Keyboards can vary by language.

## Touchpad

The touchpad settings and components are described here.

### Touchpad settings

You learn how to adjust the touchpad settings and components here.

#### Adjusting touchpad settings

Use these steps to adjust touchpad settings and gestures.

1. Type `touchpad settings` in the taskbar search box, and then press `enter`.
2. Choose a setting.

#### Turning on the touchpad

Follow these steps to turn on the touchpad.

1. Type `touchpad settings` in the taskbar search box, and then press `enter`.
2. Using an external mouse, click the **Touchpad** button.

If you are not using an external mouse, press the `Tab` key repeatedly until the pointer rests on the **touchpad** button. Then press the `spacebar` to select the button.

## Touchpad components

Use the illustration and table to identify the touchpad components.

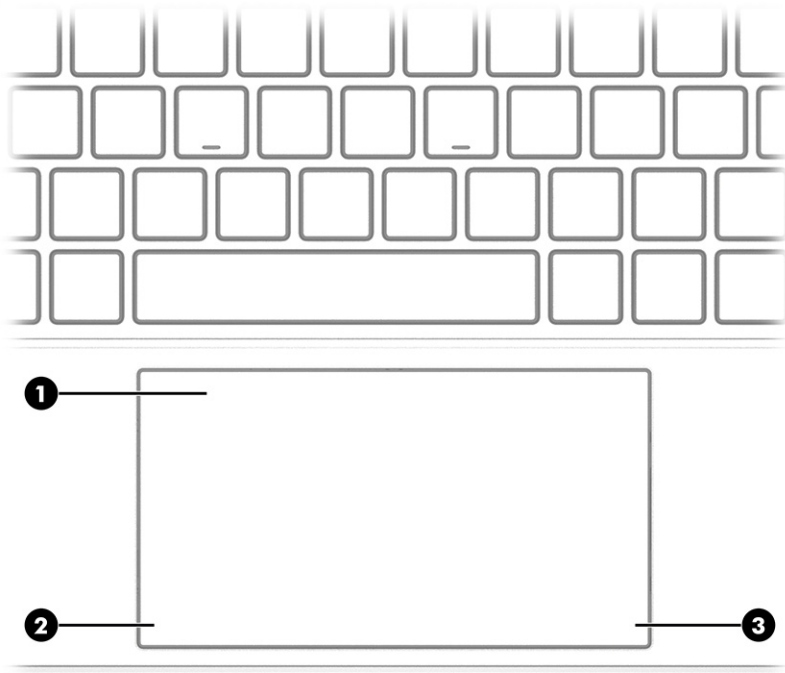
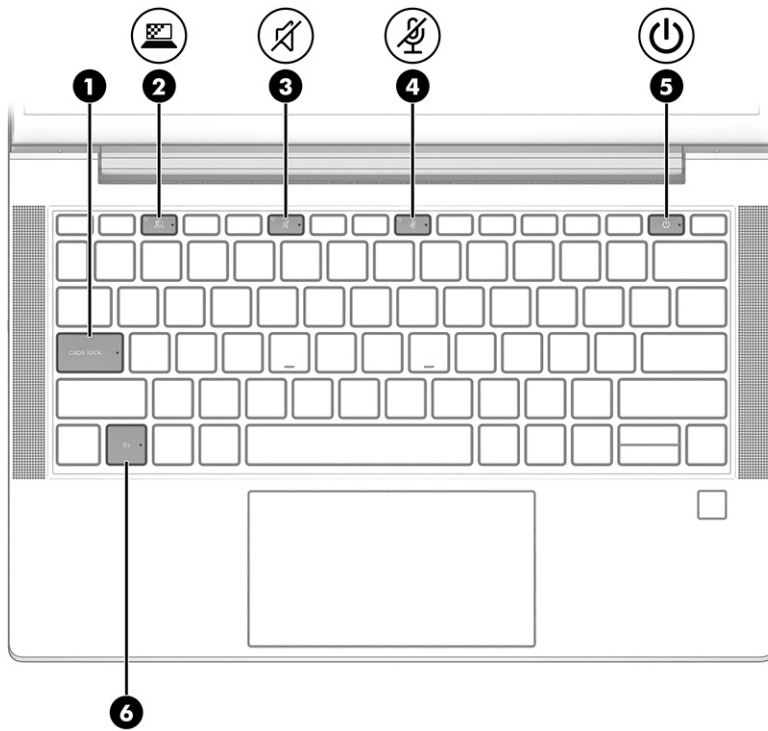

**Table 2-4** Touchpad components and their descriptions





Component	Description
(1) Touchpad zone	Reads your finger gestures to move the pointer or activate items on the screen.
(2) Left touchpad button	Functions like the left button on an external mouse.
(3) Right touchpad button	Functions like the right button on an external mouse.

## Lights

Use the illustration and table to identify the lights on the computer.



**Table 2-5** Lights and their descriptions

Component	Description
(1) Caps lock light	On: Caps lock is on, which switches the key input to all capital letters.
(2)  Privacy key light (select products only)	On: Privacy screen is on, which helps prevent side-angle viewing.
(3)  Mute light	<ul style="list-style-type: none"> <li>On: Computer sound is off.</li> <li>Off: Computer sound is on.</li> </ul>
(4)  Microphone mute light	<ul style="list-style-type: none"> <li>On: Microphone is off.</li> <li>Off: Microphone is on.</li> </ul>
(5)  Power light	<ul style="list-style-type: none"> <li>On: The computer is on.</li> <li>Blinking (select products only): The computer is in the Sleep state, a power-saving state. The computer shuts off power to the display and other unnecessary components.</li> <li>Off: Depending on your computer model, the computer is off, in Hibernation, or in Sleep. Hibernation is the power-saving state that uses the least amount of power.</li> </ul>
(6) Fn lock light	On: The fn key is locked.



## Button, speakers, and fingerprint reader

Fingerprint readers can be located on the touchpad, on a side panel of the computer, or on the top cover below the keyboard.

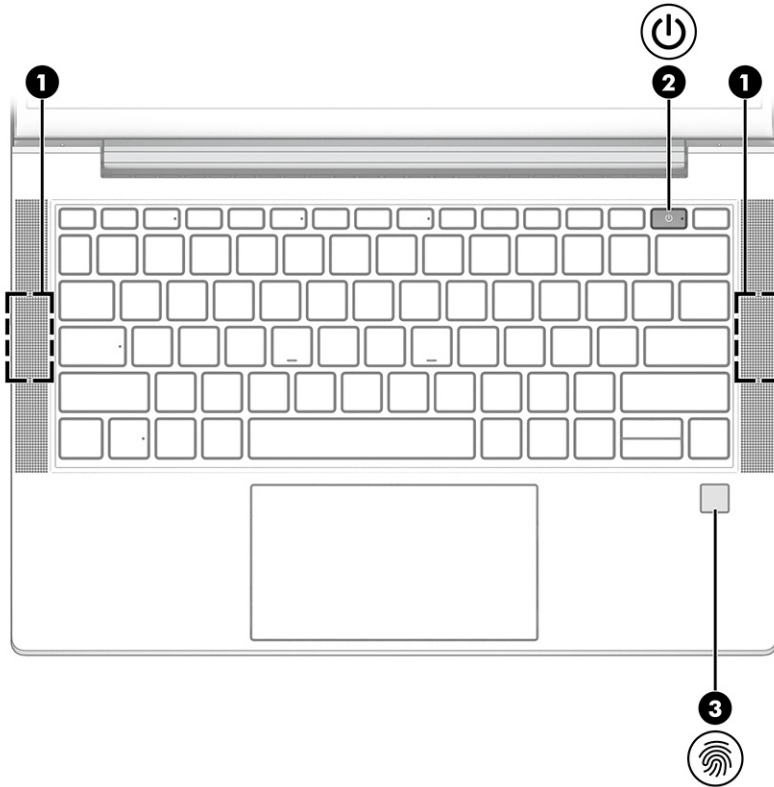
 **IMPORTANT:** To verify that your computer supports fingerprint reader sign-in, type *Sign-in options* in the taskbar search box and follow the on-screen instructions. If **Fingerprint reader** is not listed as an option, then your notebook does not include a fingerprint reader.



**Table 2-6** Button, speakers, and fingerprint reader and their descriptions

Component	Description
(1) Speakers (2)	Produce sound.
(2)  Power button	<ul style="list-style-type: none"> <li>When the computer is off, press the button briefly to turn on the computer.</li> <li>When the computer is on, press the button briefly to initiate Sleep.</li> <li>When the computer is in the Sleep state, press the button briefly to exit Sleep (select products only).</li> <li>When the computer is in Hibernation, press the button briefly to exit Hibernation.</li> </ul> <p><b>IMPORTANT:</b> Pressing and holding down the power button results in the loss of unsaved information.</p> <p>If the computer stops responding and shutdown procedures are ineffective, press and hold the power button for at least 4 seconds to turn off the computer.</p> <p>To learn more about your power settings, see your power options.</p> <p>▲ Right-click the <b>Power meter</b> icon  and then select <b>Power Options</b>.</p>

**Table 2-6** Button, speakers, and fingerprint reader and their descriptions (continued)

Component	Description
(3) Fingerprint reader (select products only)	<p>Allows a fingerprint logon to Windows, instead of a password logon.</p> <p>▲ Touch your finger to the fingerprint reader.</p> <p><b>IMPORTANT:</b> To prevent fingerprint logon issues, be sure when you register your fingerprint that all sides of your finger are registered by the fingerprint reader.</p>

## Special keys

Use the illustration and table to identify the special keys.

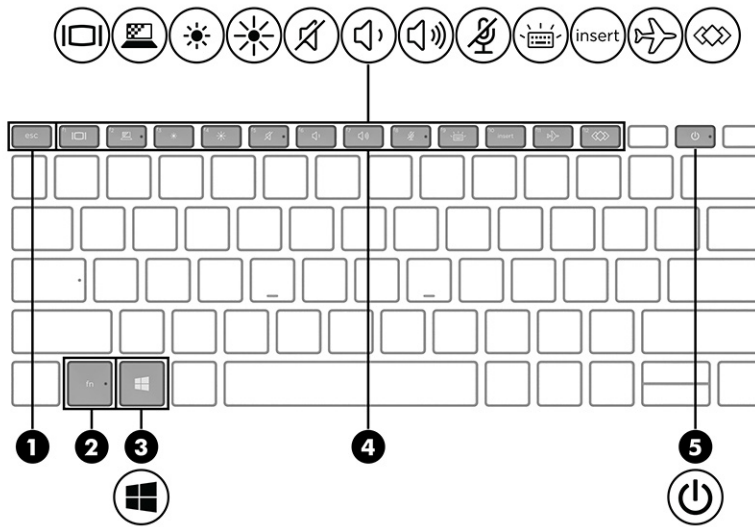

**Table 2-7** Special keys and their descriptions



Component	Description
(1) <code>esc</code> key	Displays system information when pressed in combination with the <code>fn</code> key.
(2) <code>fn</code> key	Executes frequently used system functions when pressed in combination with another key. Such key combinations are called <i>hot keys</i> .
(3)  Windows key	<p>Opens the Start menu.</p> <p><b>NOTE:</b> Pressing the Windows key again will close the Start menu.</p>
(4) Action keys	Execute frequently used system functions.
(5)  Power button	<ul style="list-style-type: none"> <li>When the computer is off, press the button briefly to turn on the computer.</li> <li>When the computer is on, press the button briefly to initiate Sleep.</li> <li>When the computer is in the Sleep state, press the button briefly to exit Sleep (select products only).</li> </ul>

Table 2-7 Special keys and their descriptions (continued)

Component	Description
	<ul style="list-style-type: none"> <li>When the computer is in Hibernation, press the button briefly to exit Hibernation.</li> </ul> <p><b>IMPORTANT:</b> Pressing and holding down the power button results in the loss of unsaved information.</p> <p>If the computer stops responding and shutdown procedures are ineffective, press and hold the power button for at least 4 seconds to turn off the computer.</p> <p>To learn more about your power settings, see your power options.</p> <p>▲ Right-click the <b>Power meter</b> icon  and then select <b>Power Options</b>.</p>

## Bottom

Use the illustration and table to identify the bottom component.

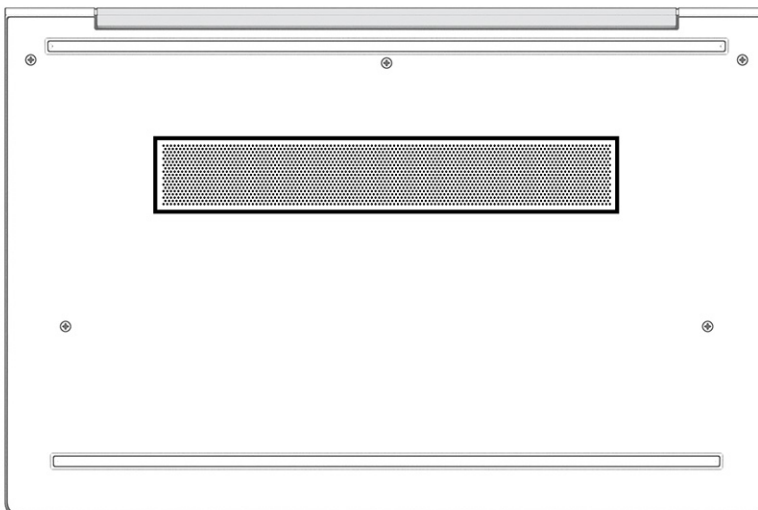

Table 2-8 Bottom component and description

Component	Description
Vent	<p>Enables airflow to cool internal components.</p> <p><b>NOTE:</b> The computer fan starts up automatically to cool internal components and prevent overheating. It is normal for the internal fan to cycle on and off during routine operation.</p>

## Labels

The labels affixed to the computer provide information you might need when you troubleshoot system problems or travel internationally with the computer. Labels might be in paper form or imprinted on the product.

**IMPORTANT:** Check the following locations for the labels described in this section: the bottom of the computer, inside the battery bay, under the service door, on the back of the display, or on the bottom of a tablet kickstand.

- Service label—Provides important information to identify your computer. When contacting support, you might be asked for the serial number, the product number, or the model number. Locate this information before you contact support.

Your service label will resemble one of these examples. Refer to the illustration that most closely matches the service label on your computer.

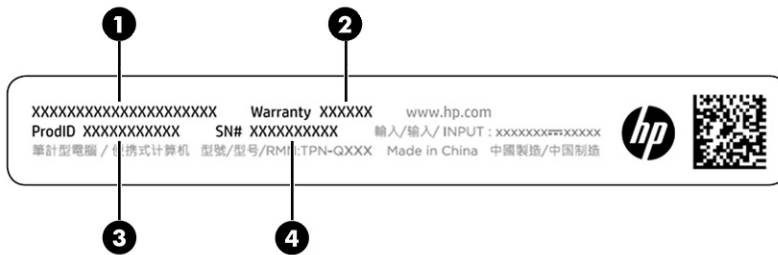

**Table 2-9** Service label components

Component
(1) HP product name
(2) Warranty period
(3) Product ID
(4) Serial number

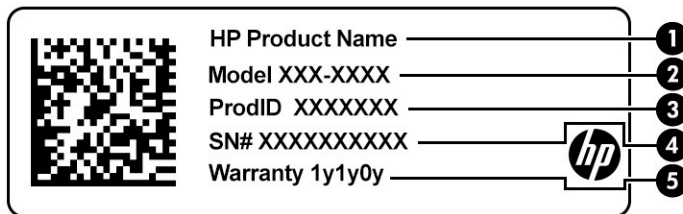

**Table 2-10** Service label components

Component
(1) HP product name
(2) Model number
(3) Product ID
(4) Serial number
(5) Warranty period

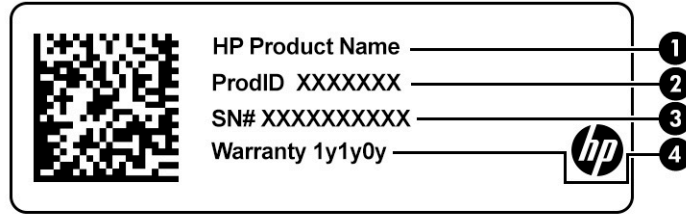



Table 2-11 Service label components

Component
(1) HP product name
(2) Product ID
(3) Serial number
(4) Warranty period

- Regulatory label(s)—Provide(s) regulatory information about the computer.
- Wireless certification label(s)—Provide(s) information about optional wireless devices and the approval markings for the countries or regions in which the devices have been approved for use.

## Using a SIM card (select products only)

Use these instructions to insert a SIM card.

 **IMPORTANT:** You can damage the SIM card if you insert the wrong size card or insert it or the SIM card tray in the wrong direction. The card might also become stuck in the slot. Do not use SIM card adapters. To prevent damage to the SIM card or connectors, use minimal force when inserting or removing a SIM card.

### Determining the correct SIM card size for your computer

Before purchasing a SIM card, follow these instructions to determine the correct SIM card size for your computer.

1. Go to <http://www.hp.com/support>, and then search for your computer by product name or number.
2. Select **Product Information**.
3. Refer to the listed options to determine which card to purchase.

### Inserting a SIM card in an external slot

To insert a SIM card in an external slot, follow these steps.

1. Turn off the computer by using the Shut down command.
2. Insert the SIM card into the SIM card slot, and then press in on the SIM card until it is firmly seated.

 **NOTE:** Your SIM card or the SIM card slot in your computer might look different from the illustration in this section.

 **NOTE:** Your SIM card slot might have an icon to show which way the card should be inserted into the computer.

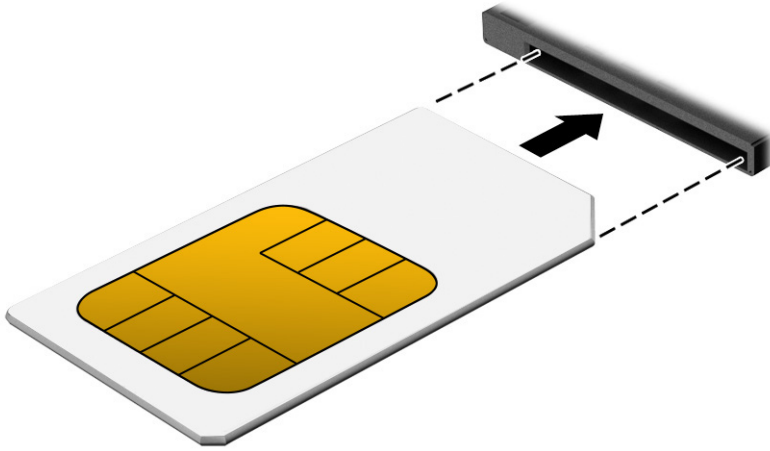

To remove the SIM card, press in gently on the card to disengage the SIM lock, and then remove it from the slot.

---

## 3 Illustrated parts catalog

Use this table to determine the spare parts that are available for the computer.

### Computer major components

To identify the computer major components, use this illustration and table.

---

 **NOTE:** HP continually improves and changes product parts. For complete and current information about supported parts for your computer, go to <http://partsurfer.hp.com>, select your country or region, and then follow the on-screen instructions.

 **NOTE:** Details about your computer, including model, serial number, product key, and length of warranty, are on the service tag at the bottom of your computer.

---

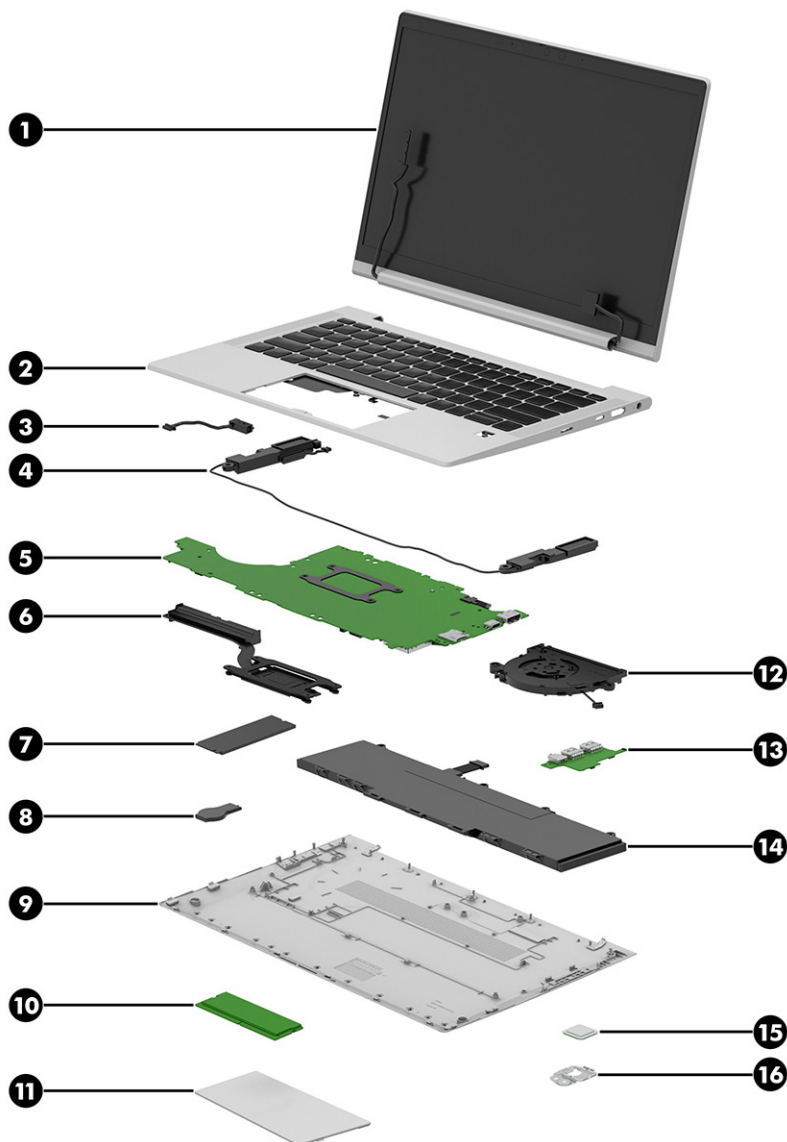

**Table 3-1** Computer major component descriptions and part numbers

Item	Component	Spare part number
(1)	Display assembly	
	<b>NOTE:</b> Display spare parts are available only as subcomponents. For spare part information, see <a href="#">Display assembly subcomponents on page 23</a> .	
(2)	<b>Top cover/keyboard with backlight and privacy filter</b> (includes backlight cable and keyboard cable):	
	For use in Belgium	M30683-A41
	For use in Brazil	M30683-201
	For use in Bulgaria	M30683-261
	For use in Canada	M30683-DB1
	For use in the Czech Republic and Slovakia	M30683-FL1
	For use in Denmark	M30683-081

**Table 3-1 Computer major component descriptions and part numbers (continued)**

Item	Component	Spare part number
	For use in Denmark, Finland, and Norway	M30683-DH1
	For use in France	M30683-051
	For use in Germany	M30683-041
	For use in Greece	M30683-151
	For use in Hungary	M30683-211
	For use in Iceland	M30683-DD1
	For use in India	M30683-D61
	For use in Israel	M30683-BB1
	For use in Japan	M30683-291
	For use in Latin America	M30683-161
	For use in the Netherlands	M30683-B31
	For use in Northwest Africa	M30683-FP1
	For use in Norway	M30683-091
	For use in Portugal	M30683-131
	For use in Romania	M30683-271
	For use in Russia	M30683-251
	For use in Saudi Arabia	M30683-171
	For use in Slovenia	M30683-BA1
	For use in South Korea	M30683-AD1
	For use in Spain	M30683-071
	For use in Sweden and Finland	M30683-B71
	For use in Switzerland	M30683-BG1
	For use in Taiwan	M30683-AB1
	For use in Thailand	M30683-281
	For use in Turkey	M30683-141
	For use in Ukraine	M30683-BD1
	For use in the United Kingdom	M30683-031
	For use in the United States	M30683-001
	<b>Top cover/keyboard with backlight</b> (includes backlight cable and keyboard cable):	
	For use in Belgium	M30681-A41
	For use in Brazil	M30681-201
	For use in Bulgaria	M30681-261
	For use in Canada	M30681-DB1
	For use in the Czech Republic and Slovakia	M30681-FL1

**Table 3-1 Computer major component descriptions and part numbers (continued)**

Item	Component	Spare part number
	For use in Denmark	M30681-081
	For use in Denmark, Finland, and Norway	M30681-DH1
	For use in France	M30681-051
	For use in Germany	M30681-041
	For use in Greece	M30681-151
	For use in Hungary	M30681-211
	For use in Iceland	M30681-DD1
	For use in India	M30681-D61
	For use in Israel	M30681-BB1
	For use in Japan	M30681-291
	For use in Latin America	M30681-161
	For use in the Netherlands	M30681-B31
	For use in Northwest Africa	M30681-FP1
	For use in Norway	M30681-091
	For use in Portugal	M30681-131
	For use in Romania	M30681-271
	For use in Russia	M30681-251
	For use in Saudi Arabia	M30681-171
	For use in Slovenia	M30681-BA1
	For use in South Korea	M30681-AD1
	For use in Spain	M30681-071
	For use in Sweden and Finland	M30681-B71
	For use in Switzerland	M30681-BG1
	For use in Taiwan	M30681-AB1
	For use in Thailand	M30681-281
	For use in Turkey	M30681-141
	For use in Ukraine	M30681-BD1
	For use in the United Kingdom	M30681-031
	For use in the United States	M30681-001
	<b>Top cover/keyboard</b> (includes keyboard cable):	
	For use in Belgium	M30682-A41
	For use in Brazil	M30682-201
	For use in Bulgaria	M30682-261
	For use in Canada	M30682-DB1

**Table 3-1 Computer major component descriptions and part numbers (continued)**

<b>Item</b>	<b>Component</b>	<b>Spare part number</b>
	For use in the Czech Republic and Slovakia	M30682-FL1
	For use in Denmark	M30682-081
	For use in Denmark, Finland, and Norway	M30682-DH1
	For use in France	M30682-051
	For use in Germany	M30682-041
	For use in Greece	M30682-151
	For use in Hungary	M30682-211
	For use in Iceland	M30682-DD1
	For use in India	M30682-D61
	For use in Israel	M30682-BB1
	For use in Japan	M30682-291
	For use in Latin America	M30682-161
	For use in the Netherlands	M30682-B31
	For use in Northwest Africa	M30682-FP1
	For use in Norway	M30682-091
	For use in Portugal	M30682-131
	For use in Romania	M30682-271
	For use in Russia	M30682-251
	For use in Saudi Arabia	M30682-171
	For use in Slovenia	M30682-BA1
	For use in South Korea	M30682-AD1
	For use in Spain	M30682-071
	For use in Sweden and Finland	M30682-B71
	For use in Switzerland	M30682-BG1
	For use in Taiwan	M30682-AB1
	For use in Thailand	M30682-281
	For use in Turkey	M30682-141
	For use in Ukraine	M30682-BD1
	For use in the United Kingdom	M30682-031
	For use in the United States	M30682-001
<b>(3)</b>	<b>Power connector cable</b>	M15626-001
<b>(4)</b>	<b>Speakers</b>	M30648-001
<b>(5)</b>	<b>System board</b> (includes integrated processor, graphics subsystem with UMA memory, replacement thermal material, and the Google Chrome™ operating system):	

**Table 3-1 Computer major component descriptions and part numbers (continued)**

Item	Component	Spare part number
	Equipped with an AMD Ryzen 7 PRO 5850U processor for use on computer models with WWAN capability	M52743-001
	Equipped with an AMD Ryzen 7 PRO 5850U processor for use on computer models without WWAN capability	M52742-001
	Equipped with an AMD Ryzen 7 PRO 5800U processor for use on computer models with WWAN capability	M52741-001
	Equipped with an AMD Ryzen 7 PRO 5800U processor for use on computer models without WWAN capability	M52740-001
	Equipped with an AMD Ryzen 5 PRO 5650U processor for use on computer models with WWAN capability	M52739-001
	Equipped with an AMD Ryzen 5 PRO 5650U processor for use on computer models without WWAN capability	M52738-001
	Equipped with an AMD Ryzen 5 PRO 5600U processor for use on computer models with WWAN capability	M52737-001
	Equipped with an AMD Ryzen 5 PRO 5600U processor for use on computer models without WWAN capability	M52736-001
	Equipped with an AMD Ryzen 3 PRO 5400U processor for use on computer models with WWAN capability	M52735-001
	Equipped with an AMD Ryzen 3 PRO 5600U processor for use on computer models without WWAN capability	M52734-001
<b>(6)</b>	<b>Heat sink</b> (includes replacement thermal material)	M30651-001
<b>(7)</b>	<b>Solid-state drive:</b>	
	1 TB, PCIe, TLC	L85348-001
	512 GB, PCIe, TLC	L85360-001
	512 GB, PCIe, value	L85364-001
	256 GB, PCIe, TLC	L85350-001
	256 GB, PCIe, value	L85354-001
	128 GB, M.2 2280, PCIe-3×2, TLC	M06792-001
<b>(8)</b>	<b>RTC battery</b>	L13694-001
<b>(9)</b>	<b>Bottom cover</b>	M30652-001
<b>(10)</b>	<b>Memory modules (DDR4, PC-3200):</b>	
	16 GB	L67710-001
	8 GB	L46598-001
	4 GB	L83673-001
<b>(11)</b>	<b>Touchpad</b>	
<b>(12)</b>	<b>Fan</b>	M30650-001
<b>(13)</b>	<b>USB board</b>	M36398-001
	<b>NOTE:</b> The USB board cable is available in the Cable Kit as spare part number M30646-001.	
<b>(14)</b>	<b>Battery:</b>	

**Table 3-1** Computer major component descriptions and part numbers (continued)

Item	Component	Spare part number
	3 cell, 53 Whr	L78555-005
	3 cell, 42 Whr	M12451-005
(15)	<b>Fingerprint reader</b> <b>NOTE:</b> The fingerprint reader cable is available in the Cable Kit as spare part number M30646-001.	M03434-001
(16)	<b>Fingerprint reader bracket</b>	M30665-001
	<b>WLAN module</b> (not illustrated):	
	Intel Wi-Fi 6 AX200 + Bluetooth 5 (non-vPro)	L35282-005
	Realtek RTL8822CE 802.11ac 2 × 2 Wi-Fi + Bluetooth 5	L44796-005
	<b>Intel XMM 7360 LTE-Advanced (Cat 9) WWAN module</b> (not illustrated)	L70760-002

## Display assembly subcomponents

To identify the display assembly subcomponents, use this illustration and table.

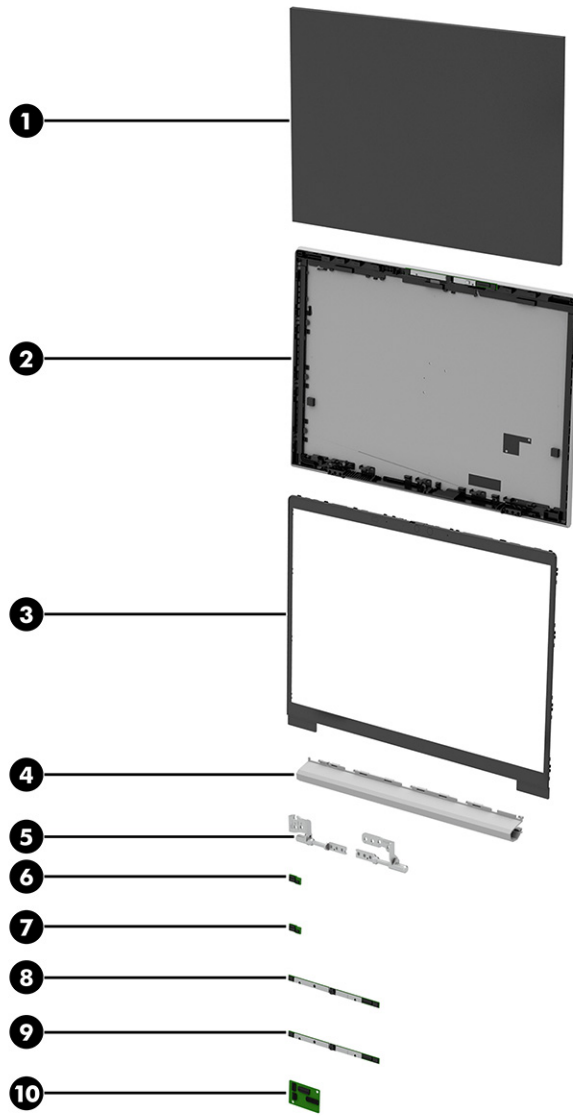

**Table 3-2** Display component descriptions and part numbers

Item	Component	Spare part number
(1)	<b>Display panel:</b>	
	For use on computer models with display panels with privacy filter	M52479-001
	For use on computer models with display panels with 400 nit brightness	M52748-001
	For use on computer models with display panels with 250 nit brightness	M52747-001
(2)	<b>Display back cover:</b>	
	Models with WWAN, thin	M75285-001
	Models with WLAN, thick	M30654-001
	Models with WLAN, thin	M30655-001

**Table 3-2 Display component descriptions and part numbers (continued)**

Item	Component	Spare part number
(3)	<b>Bezel:</b>	
	For use in models with an IR camera and ambient light sensor	M30658-001
	For use in models with an IR camera	M30657-001
	For use in models with an RGB camera	M30656-001
	For use in models with a microphone module (no camera)	M30659-001
(4)	<b>Hinge cover</b> (included in Plastics Kit)	M30663-001
(5)	<b>Hinges</b> (left and right)	M30666-001
	<b>Ambient light sensor board:</b>	
(6)	For use on computer models without privacy filter and without WWAN capability	M30669-001
(7)	For use on computer models with privacy filter and with WWAN capability	M44355-001
(8)	<b>HD camera module</b>	M30660-001
(9)	<b>IR camera module</b>	M30661-001
	<b>Microphone module</b>	M30671-001
(10)	<b>Hub board</b>	
	For use in models with an RGB camera or microphone module	M30672-001
	For use in models with an IR camera	M30673-001
	<b>LCD Support Kit</b> (includes double-sided tape and foam sponge; not illustrated)	M33161-001
	<b>Display cable</b> (included in Display Cable Kit; not illustrated)	M30647-001
	<b>Camera cable</b> (included in Cable Kit; not illustrated)	M30646-001

## Cable Kit

To identify the contents of the Cable Kit, use this table.

**Table 3-3 Cable Kit content descriptions and part number**

Component	Spare part number
<b>Cable Kit</b> , includes:	M30646-001
Hub board to system board cable	
IR camera to hub board cable	
Ambient light sensor to hub board cable	
Ambient light sensor to hub board cable (privacy models with WWAN)	
Ambient light sensor to display panel (privacy models with WWAN)	
Dual ambient light sensor to hub board cable	
Touchpad cable	
Fingerprint reader board cable	

**Table 3-3 Cable Kit content descriptions and part number (continued)**

Component	Spare part number
USB board to system board cable (2)	
Camera/microphone module to hub board cable	

## Plastics Kit

To identify the Plastics Kit components, use this table.

**Table 3-4 Plastics Kit component descriptions and part numbers**

Component	Spare part number
<b>Plastics Kit</b> , includes:	M30663-001
I/O bracket	
SIM card insert	
Hinge cover	
WWAN insulator	
Fingerprint reader insert	
Fingerprint reader gasket	
Display bezel plate protective tape	
Ambient light sensor protective tape	
Memory module protective shield (for models without WWAN)	
Solid-state drive protective shield	

## Miscellaneous parts

To identify the miscellaneous parts, use this table.

**Table 3-5 Miscellaneous part descriptions and part numbers**

Component	Spare part number
<b>AC adapter:</b>	
120 W, HP Smart Adapter, PFC slim, 7.4 mm	L57117-001
65 W, nPFC, SMART, 3 pin, 4.5 mm	710412-001
65 W, nPFC, SMART, 4.5 mm, EM	913691-850
65 W, nPFC, USB-C, 1.8 m [5.9 ft]	L67440-001
45 W, nPFC, SMART, RC, 4.5 mm, nonslim	741727-001
45 W, nPFC, SMART, RC, 4.5 mm, 2 pin	742436-001
45 W, nPFC, USB-C, wall mount, 1.8 m [5.9 ft]	L43407-001
<b>Rubber Kit</b> (includes top support bumper and antenna bumpers)	M30667-001
<b>Miscellaneous Kit</b> (includes memory module cover, solid-state drive cover, and SIM tray)	M33155-001

**Table 3-5** Miscellaneous part descriptions and part numbers (continued)

Component	Spare part number
<b>Screw Kit</b>	M30668-001
<b>Power adapter, duckhead</b>	
Japan	L33157-001
<b>Power cord (C7, conventional, 1.0 m [3.3 ft])</b>	
Japan	L19375-001
<b>Power cord (C5, conventional, 1.0 m [3.3 ft])</b>	
Argentina	L19357-001
Australia	L19358-001
Brazil	L19359-001
Denmark	L19360-001
Europe (Austria, Belgium, Finland, France, Germany, the Netherlands, Norway, and Sweden)	L19361-001
India	L19363-001
Israel	L19362-001
Italy	L19364-001
Japan	L19365-001
North America	L19367-001
People's Republic of China	L19368-001
South Africa	L19369-001
South Korea	L19366-001
Switzerland	L19370-001
Taiwan	L19372-001
Thailand	L19371-001
The United Kingdom	L19373-001
<b>Power cord (C5, conventional, 1.8 m, [6 ft])</b>	
Argentina	L19357-002
Australia	L19358-002
Brazil	L19359-002
Denmark	L19360-002
Europe (Austria, Belgium, Finland, France, Germany, the Netherlands, Norway, and Sweden)	L19361-002
India	L19363-002
Israel	L19362-002
Italy	L19364-002
Japan	L19365-002
North America	L19367-002

**Table 3-5** Miscellaneous part descriptions and part numbers (continued)

<b>Component</b>	<b>Spare part number</b>
People's Republic of China	L19368-002
South Africa	L19369-002
South Korea	L19366-002
Switzerland	L19370-002
Taiwan	L19372-002
Thailand	L19371-002
The United Kingdom	L19373-002

---

## 4 Removal and replacement procedures preliminary requirements

Use this information to properly prepare to disassemble and reassemble the computer.

### Tools required

You need the following tools to complete the removal and replacement procedures:

- Tweezers
- Nonconductive, nonmarking pry tool
- Magnetic Phillips P1 screwdriver

### Service considerations

The following sections include some of the considerations that you must keep in mind during disassembly and assembly procedures.

---

 **NOTE:** As you remove each subassembly from the computer, place the subassembly (and all accompanying screws) away from the work area to prevent damage.

---

### Plastic parts

Using excessive force during disassembly and reassembly can damage plastic parts.

### Cables and connectors

Handle cables with extreme care to avoid damage.

---

 **IMPORTANT:** When servicing the computer, be sure that cables are placed in their proper locations during the reassembly process. Improper cable placement can damage the computer.

---

Apply only the tension required to unseat or seat the cables during removal and insertion. Handle cables by the connector whenever possible. In all cases, avoid bending, twisting, or tearing cables. Be sure that cables are routed so that they cannot be caught or snagged as you remove or replace parts. Handle flex cables with extreme care; these cables tear easily.

## Drive handling

Note the following guidelines when handling drives.

---

 **IMPORTANT:** Drives are fragile components. Handle them with care. To prevent damage to the computer, damage to a drive, or loss of information, observe these precautions:

Before removing or inserting a hard drive, shut down the computer. If you are unsure whether the computer is off or in Hibernation, turn the computer on, and then shut it down through the operating system.

Before handling a drive, be sure that you are discharged of static electricity. While handling a drive, avoid touching the connector.

Before removing an optical drive, be sure that a disc is not in the drive, and be sure that the optical drive tray is closed.

Handle drives on surfaces covered with at least 2.54 cm (1 inch) of shock-proof foam.

Avoid dropping drives from any height onto any surface.

After removing a hard drive or an optical drive, place it in a static-proof bag.

Avoid exposing an internal hard drive to products that have magnetic fields, such as monitors or speakers.

Avoid exposing a drive to temperature extremes or liquids.

If a drive must be mailed, place the drive in a bubble pack mailer or other suitable form of protective packaging, and label the package “FRAGILE.”

---

## Electrostatic discharge information

A sudden discharge of static electricity from your finger or other conductor can destroy static-sensitive devices or microcircuitry. Often the spark is neither felt nor heard, but damage occurs. An electronic device exposed to electrostatic discharge (ESD) might not appear to be affected at all and can work perfectly throughout a normal cycle. The device might function normally for a while, but it has been degraded in the internal layers, reducing its life expectancy.

Networks built into many integrated circuits provide some protection, but in many cases, the discharge contains enough power to alter device parameters or melt silicon junctions.

---

 **IMPORTANT:** To prevent damage to the device when you remove or install internal components, observe these precautions:

Keep components in their electrostatic-safe containers until you are ready to install them.

Before touching an electronic component, discharge static electricity by using the guidelines described [Personal grounding methods and equipment on page 31](#).

Avoid touching pins, leads, and circuitry. Handle electronic components as little as possible.

If you remove a component, place it in an electrostatic-safe container.

---

## Generating static electricity

Follow these static electricity guidelines.

- Different activities generate different amounts of static electricity.

- Static electricity increases as humidity decreases.

**Table 4-1 Static electricity occurrence based on activity and humidity**

Event	Relative humidity		
	55%	40%	10%
Walking across carpet	7,500 V	15,000 V	35,000 V
Walking across vinyl floor	3,000 V	5,000 V	12,000 V
Motions of bench worker	400 V	800 V	6,000 V
Removing DIPs (dual in-line packages) from plastic tube	400 V	700 V	2,000 V
Removing DIPs from vinyl tray	2,000 V	4,000 V	11,500 V
Removing DIPs from polystyrene foam	3,500 V	5,000 V	14,500 V
Removing bubble pack from PCB (printed circuit board)	7,000 V	20,000 V	26,500 V
Packing PCBs in foam-lined box	5,000 V	11,000 V	21,000 V

Multiple electric components can be packaged together in plastic tubes, trays, or polystyrene foam.

 **NOTE:** As little as 700 V can degrade a product.

## Preventing electrostatic damage to equipment

Many electronic components are sensitive to ESD. Circuitry design and structure determine the degree of sensitivity. The following packaging and grounding precautions are necessary to prevent static electricity damage to electronic components.

- To avoid hand contact, transport products in static-safe containers such as tubes, bags, or boxes.
- Protect all electrostatic parts and assemblies with conductive or approved containers or packaging.
- Keep electrostatic-sensitive parts in their containers until they arrive at static-free stations.
- Place items on a grounded surface before removing them from their container.
- Always be properly grounded when touching a sensitive component or assembly.
- Avoid contact with pins, leads, or circuitry.
- Place reusable electrostatic-sensitive parts from assemblies in protective packaging or conductive foam.

## Personal grounding methods and equipment

Using certain equipment can prevent static electricity damage to electronic components.

- **Wrist straps** are flexible straps with a maximum of  $1\text{ M}\Omega \pm 10\%$  resistance in the ground cords. To provide proper ground, a strap must be worn snug against bare skin. The ground cord must be connected and fit snugly into the banana plug connector on the grounding mat or workstation.
- **Heel straps/Toe straps/Boot straps** can be used at standing workstations and are compatible with most types of shoes or boots. On conductive floors or dissipative floor mats, use them on both feet with a maximum of  $1\text{ M}\Omega \pm 10\%$  resistance between the operator and ground.

**Table 4-2 Static shielding protection levels**

Static shielding protection levels	
Method	Voltage
Antistatic plastic	1,500
Carbon-loaded plastic	7,500
Metallized laminate	15,000

## Grounding the work area

To prevent static damage at the work area, follow these precautions.

- Cover the work surface with approved static-dissipative material.
- Use a wrist strap connected to a properly grounded work surface and use properly grounded tools and equipment.
- Use static-dissipative mats, foot straps, or air ionizers to give added protection.
- Handle electrostatic sensitive components, parts, and assemblies by the case or PCB laminate. Handle them only at static-free work areas.
- Turn off power and input signals before inserting and removing connectors or test equipment.
- Use fixtures made of static-safe materials when fixtures must directly contact dissipative surfaces.
- Keep the work area free of nonconductive materials, such as ordinary plastic assembly aids and polystyrene foam.
- Use conductive field service tools, such as cutters, screwdrivers, and vacuums.
- Avoid contact with pins, leads, or circuitry.

## Recommended materials and equipment

HP recommends certain materials and equipment to prevent static electricity.

- Antistatic tape
- Antistatic smocks, aprons, or sleeve protectors
- Conductive bins and other assembly or soldering aids
- Conductive foam
- Conductive tabletop workstations with ground cord of  $1\text{ M}\Omega \pm 10\%$  resistance
- Static-dissipative table or floor mats with hard tie to ground
- Field service kits
- Static awareness labels
- Wrist straps and footwear straps providing  $1\text{ M}\Omega \pm 10\%$  resistance
- Material handling packages

- Conductive plastic bags
- Conductive plastic tubes
- Conductive tote boxes
- Opaque shielding bags
- Transparent metallized shielding bags
- Transparent shielding tubes

## Packaging and transporting guidelines

Follow these grounding guidelines when packaging and transporting equipment.

- To avoid hand contact, transport products in static-safe tubes, bags, or boxes.
- Protect ESD-sensitive parts and assemblies with conductive or approved containers or packaging.
- Keep ESD-sensitive parts in their containers until the parts arrive at static-free workstations.
- Place items on a grounded surface before removing items from their containers.
- Always be properly grounded when touching a component or assembly.
- Store reusable ESD-sensitive parts from assemblies in protective packaging or nonconductive foam.
- Use transporters and conveyors made of antistatic belts and roller bushings. Be sure that mechanized equipment used for moving materials is wired to ground and that proper materials are selected to avoid static charging. When grounding is not possible, use an ionizer to dissipate electric charges.



---

# 5 Removal and replacement procedures for Customer Self-Repair parts

This chapter provides removal and replacement procedures for Customer Self-Repair parts.

---

 **NOTE:** The Customer Self-Repair program is not available in all locations. Installing a part that is not supported by the Customer Self-Repair program can void your warranty. Check your warranty to determine whether Customer Self-Repair is supported in your location.

---

## Component replacement procedures

To remove and replace computer components, use these procedures.

---

 **NOTE:** Details about your computer, including model, serial number, product key, and length of warranty, are on the service tag at the bottom of your computer.

 **NOTE:** HP continually improves and changes product parts. For complete and current information about supported parts for your computer, go to <http://partsurfer.hp.com>, select your country or region, and then follow the on-screen instructions.

---

You must remove, replace, or loosen as many as 6 screws when you service Customer Self-Repair parts. Make special note of each screw size and location during removal and replacement.

## Preparation for disassembly

To prepare to disassemble the computer, use these steps.

See [Removal and replacement procedures preliminary requirements on page 29](#) for initial safety procedures.

1. Turn off the computer. If you are unsure whether the computer is off or in Hibernation, turn the computer on, and then shut it down through the operating system.
2. Disconnect the power from the computer by unplugging the power cord from the computer.
3. Disconnect all external devices from the computer.

## Bottom cover

To remove the bottom cover, use this procedure and illustration.

**Table 5-1** Bottom cover description and part number

Description	Spare part number
Bottom cover	M30652-001

Before removing the bottom cover, prepare the computer for disassembly (see [Preparation for disassembly on page 35](#)).

Remove the bottom cover:

1. Loosen the five captive Phillips screws that secure the bottom cover to the computer.

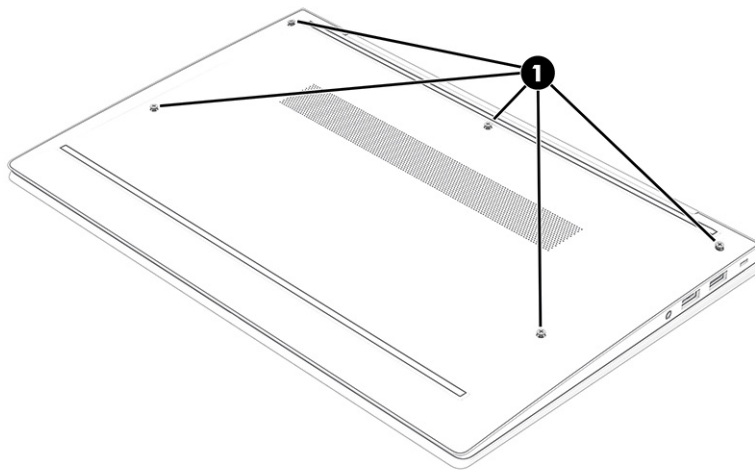

2. Starting near the hinges, use a nonmarking, nonconductive tool to release the edges of the bottom cover from the computer (1).

3. Remove the bottom cover from the computer (2).

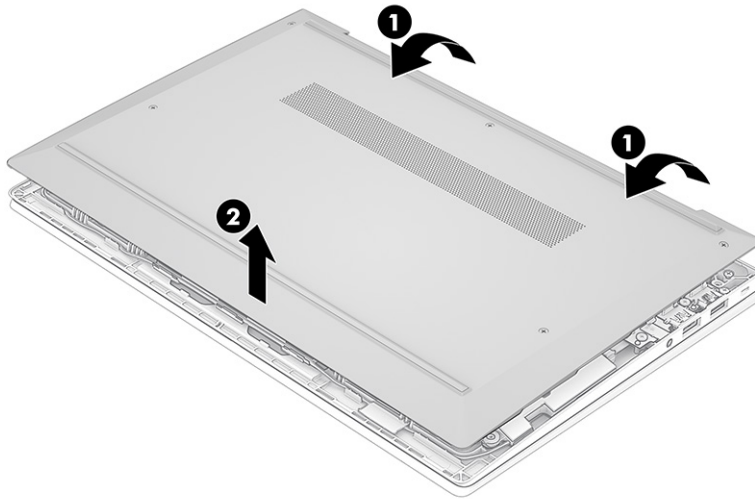

To replace the bottom cover, reverse the removal procedures.

## Memory modules

To remove the memory modules, use this procedure and illustration.

**Table 5-2** Memory module descriptions and part numbers

Description	Spare part number
16 GB, DDR4-3200	L67710-001
8 GB, DDR4-3200	L46598-001
4 GB, DDR4-3200	L83673-001
Memory module cover (included in Miscellaneous Parts Kit)	M30663-001

Before removing the memory, follow these steps:

1. Prepare the computer for disassembly (see [Preparation for disassembly on page 35](#)).
2. Remove the bottom cover (see [Bottom cover on page 35](#)).
3. Disconnect the battery cable from the system board (see [Battery on page 43](#)).

If you are replacing a memory module, remove the existing memory module:

1. Use the tab (1) to lift the cover off the memory modules (2). The cover is held in place by clips on the system board.

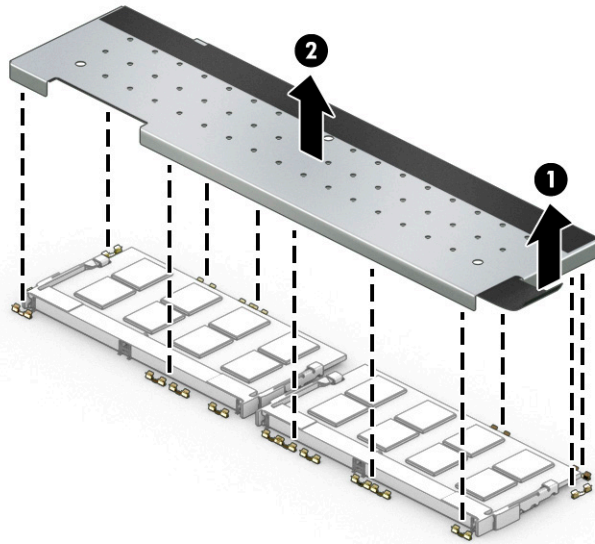

2. Spread the two retention clips outward (1) until the memory module tilts up at a 45° angle, and then remove the module (2). Use the same procedure to remove all memory modules.

 **IMPORTANT:** To prevent damage to the memory module, hold the memory module by the edges only. Do not touch the components on the memory module.

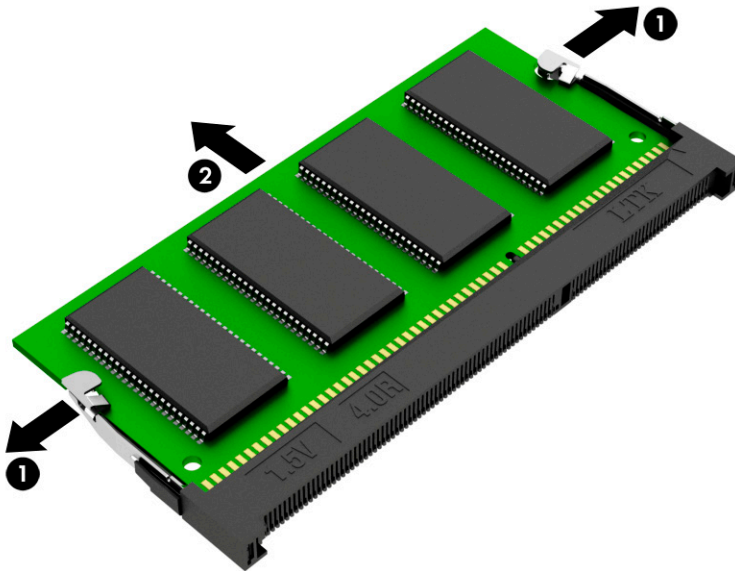

To protect a memory module after removal, place it in an electrostatic-safe container.

To install a memory module:

1. Align the notched edge of the module with the tab in the slot (1), and then press the module into the slot at an angle until it is seated (2).

2. Press down on the module until the side retention clips snap into place (3).

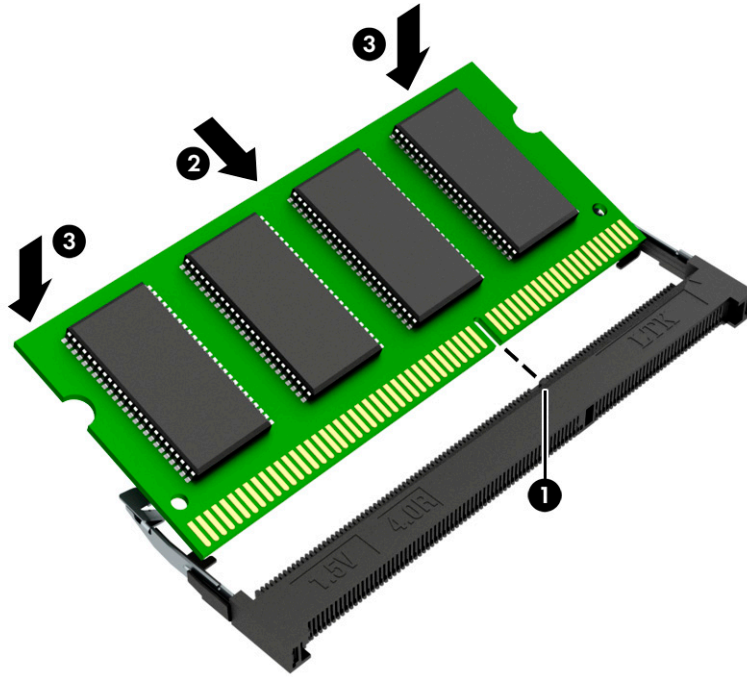

3. Replace the cover by inserting the edges of the cover into the clips on the system board that surround the memory modules (1).

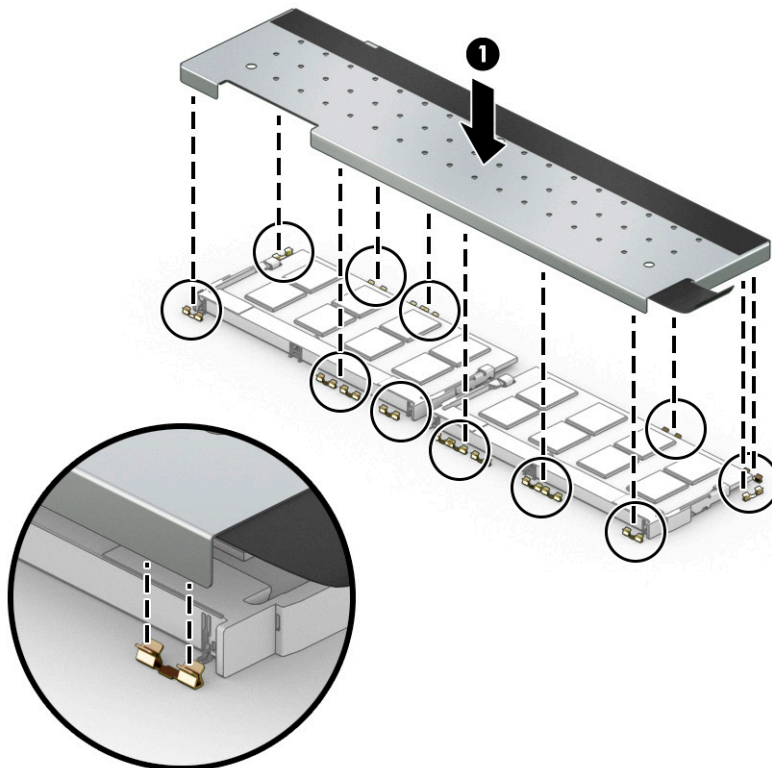

## Solid-state drive

To remove the M.2 solid-state drive, use this procedure and illustration.

**Table 5-3 Solid-state drive descriptions and part numbers**

Description	Spare part number
1 TB, PCIe, TLC	L85348-001
512 GB, PCIe, TLC	L85360-001
512 GB, PCIe, value	L85364-001
256 GB, PCIe, TLC	L85350-001
256 GB, PCIe, value	L85354-001
128 GB, M.2 2280, PCIe-3×2, TLC	M06792-001
Solid-state drive cover (included in Miscellaneous Parts Kit)	M30663-001

Before removing the solid-state drive, follow these steps:

1. Prepare the computer for disassembly (see [Preparation for disassembly on page 35](#)).
2. Remove the bottom cover (see [Bottom cover on page 35](#)).
3. Disconnect the battery cable from the system board (see [Battery on page 43](#)).

Remove the solid-state drive:

- ▲ Use the tab **(1)** to lift the cover off the solid-state drive **(2)**. The cover is held in place by clips on the system board.

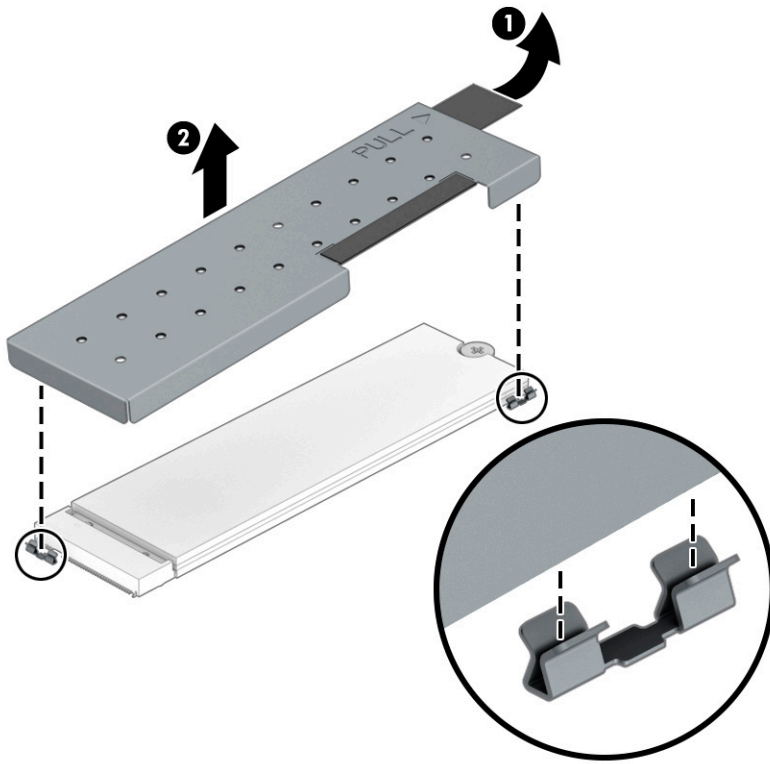

1. Remove the Phillips M2.0 × 2.5 screw (1) that secures the drive to the computer.
2. Pull the drive away from the socket to remove it (2).

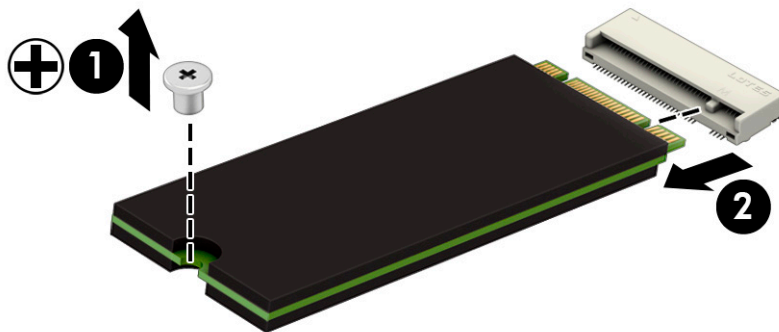

3. Replace the cover by inserting the edges of the cover into the clips on the system board near the sides of the solid-state drive.

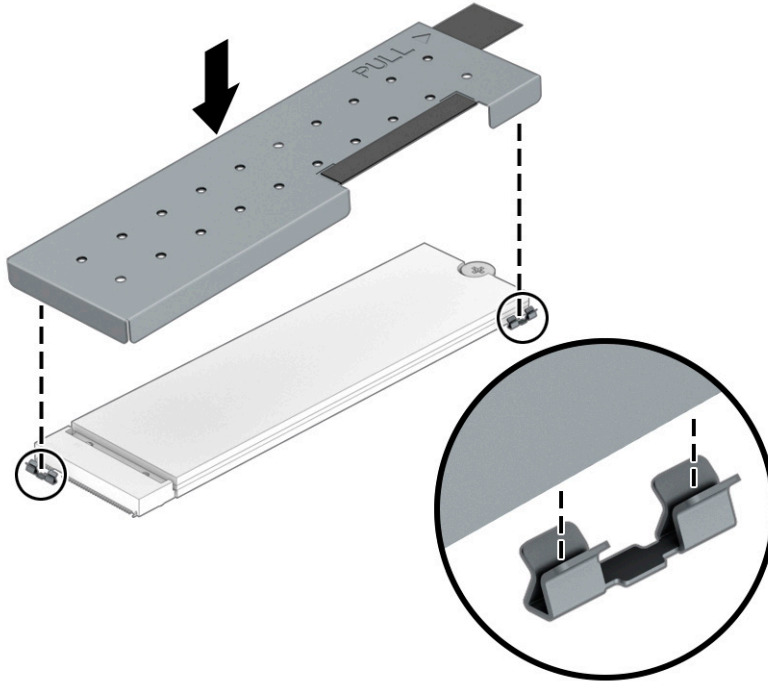

To install the solid-state drive, reverse the removal procedures.

---

 **NOTE:** Solid-state drives are designed with a notch to prevent incorrect insertion.

---

---

# 6 Removal and replacement procedures for authorized service provider parts

This chapter provides removal and replacement procedures for authorized service provider parts.

 **IMPORTANT:** Components described in this chapter should be accessed only by an authorized service provider. Accessing these parts can damage the computer or void the warranty.

 **NOTE:** Details about your computer, including model, serial number, product key, and length of warranty, are on the service tag at the bottom of your computer.

---

## Component replacement procedures

To remove and replace computer components, use these procedures.

 **NOTE:** HP continually improves and changes product parts. For complete and current information about supported parts for your computer, go to <http://partsurfer.hp.com>, select your country or region, and then follow the on-screen instructions.

---

You must remove, replace, or loosen as many as 40 screws when you service the parts described in this chapter. Make special note of each screw size and location during removal and replacement.

## Preparation for disassembly

To remove and replace computer components, use these procedures.

See [Removal and replacement procedures preliminary requirements on page 29](#) for initial safety procedures.

1. Turn off the computer. If you are unsure whether the computer is off or in Hibernation, turn the computer on, and then shut it down through the operating system.
2. Disconnect the power from the computer by unplugging the power cord from the computer.
3. Disconnect all external devices from the computer.

## Battery

To remove the battery, use this procedure and illustration.

**Table 6-1** Battery descriptions and part numbers

Description	Spare part number
Battery, 3 cell, 53 Whr	L78555-005

Table 6-1 Battery descriptions and part numbers (continued)

Description	Spare part number
Battery, 3 cell, 42 Whr	M12451-005

 **WARNING!** To avoid personal injury and damage to the product:

- Do *not* puncture, twist, or crack the battery.
- Do *not* cause an external puncture or rupture to the battery. They can cause a short inside the battery, which can result in battery thermal runaway.
- Do *not* handle or touch the battery enclosure with sharp objects such as tweezers or pliers, which might puncture the battery.
- Do *not* compress or squeeze the battery case with tools or heavy objects stacked on top of the case. These actions can apply undue force on the battery.
- Do *not* touch the connectors with any metallic surface or object, such as metal tools, screws, or coins, which can cause shorting across the connectors.

Before removing the battery, follow these steps:

1. Prepare the computer for disassembly (see [Preparation for disassembly on page 43](#)).
2. Remove the bottom cover (see [Bottom cover on page 35](#)).

 **WARNING!** To reduce potential safety issues, use only the user-replaceable battery provided with the computer, a replacement battery provided by HP, or a compatible battery purchased from HP.

 **IMPORTANT:** Removing a battery that is the sole power source for the computer can cause loss of information. To prevent loss of information, save your work or shut down the computer through Windows before you remove the battery.

Remove the battery:

1. Disconnect the battery cable from the system board **(1)**.
2. Remove the speaker cable from the clips along the bottom of the battery **(2)**.
3. Remove the four Phillips M2.0 × 4.0 screws **(3)** that secure the battery to the computer.

4. Rotate the top of the battery up, and then pull it away from the bottom of the computer to remove it (4).

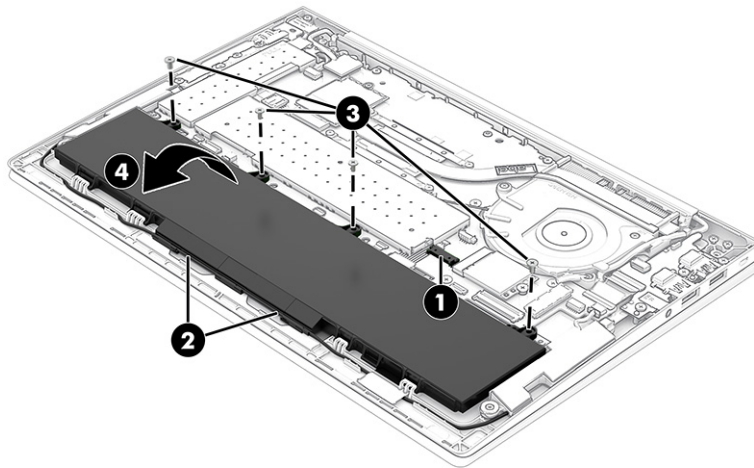

To insert the battery, reverse the removal procedures.

## WLAN module

To remove the WLAN module, use this procedure and illustration.

**Table 6-2** WLAN module descriptions and part numbers

Description	Spare part number
Intel Wi-Fi 6 AX200 + Bluetooth 5 (non-vPro)	L35282-005
Realtek RTL8822CE 802.11ac 2 × 2 Wi-Fi + Bluetooth 5	L44796-005

**IMPORTANT:** To prevent an unresponsive system, replace the wireless module only with a wireless module authorized for use in the computer by the governmental agency that regulates wireless devices in your country or region. If you replace the module and then receive a warning message, remove the module to restore device functionality, and then contact technical support.

Before removing the WLAN module, follow these steps:

1. Prepare the computer for disassembly (see [Preparation for disassembly on page 43](#)).
2. Remove the bottom cover (see [Bottom cover on page 35](#)).
3. Disconnect the battery cable from the system board (see [Battery on page 43](#)).

Remove the WLAN module:

1. Carefully disconnect the two antenna cables from the module (1).
2. Remove the Phillips M2.0 × 2.5 screw (2), and then remove the WLAN module (3).

**NOTE:** Models have either one or two WLAN antennas. On models with two antennas, the #1 white WLAN antenna cable connects to the WLAN module #1 Main terminal. The #2 black WLAN antenna cable connects to the WLAN module #1 Aux terminal.

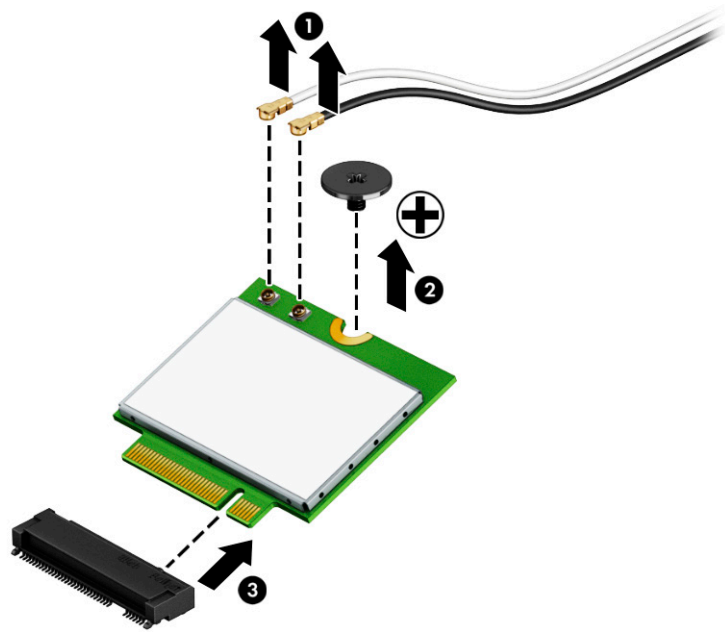

3. If the WLAN antenna is not connected to the terminal on the WLAN module, install a protective sleeve on the antenna connector, as shown in the following illustration.

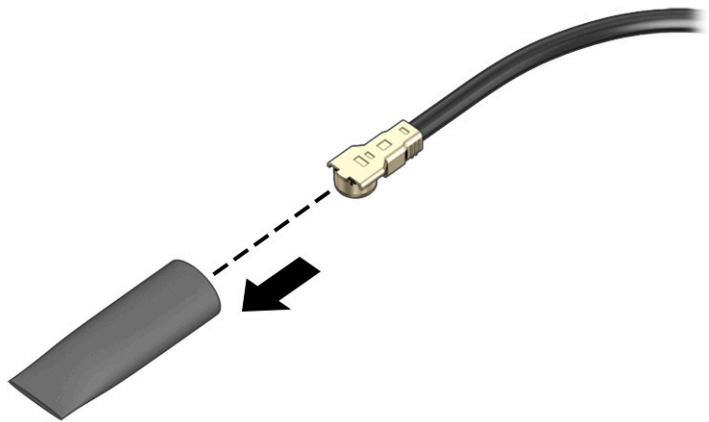

Reverse this procedure to install the WLAN module.

## WWAN module

To remove the WWAN module, use this procedure and illustration.

**Table 6-3 WWAN module description and part number**

Description	Spare part number
Intel XMM 7360 LTE-Advanced (Cat 9)	M70670-002

 **IMPORTANT:** To prevent an unresponsive system, replace the wireless module only with a wireless module authorized for use in the computer by the governmental agency that regulates wireless devices in your country or region. If you replace the module and then receive a warning message, remove the module to restore device functionality, and then contact technical support.

Before removing the WWAN module, follow these steps:

1. Prepare the computer for disassembly (see [Preparation for disassembly on page 43](#)).
2. Remove the bottom cover (see [Bottom cover on page 35](#)).
3. Disconnect the battery cable from the system board (see [Battery on page 43](#)).

Remove the WWAN module:

1. Remove the protective piece from the antenna connectors **(1)**.
2. Disconnect the WWAN antenna cables **(2)** from the terminals on the WWAN module.
3. Remove the Phillips M2.0 × 2.0 screw **(3)** that secures the WWAN module to the bottom cover. (The WWAN module tilts up.)
4. Remove the WWAN module **(4)** by pulling the module away from the slot at an angle.

 **NOTE:** When viewed with the antenna terminals at the top of the module, the white WWAN antenna cables connects to the terminal to the left of the black WWAN antenna cables.

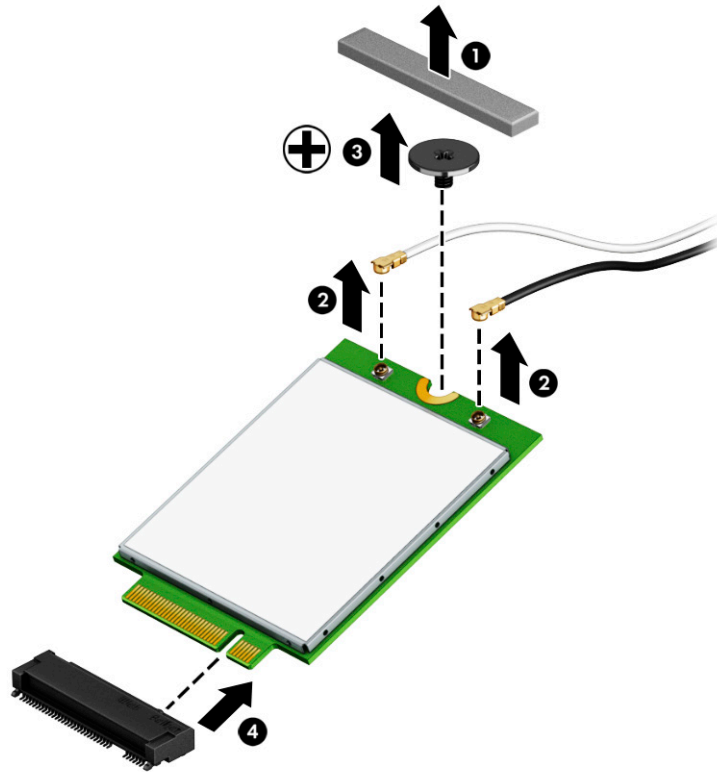

5. If the WWAN antenna is not connected to the terminal on the WWAN module, a protective sleeve must be installed on the antenna connector, as shown in the following illustration.

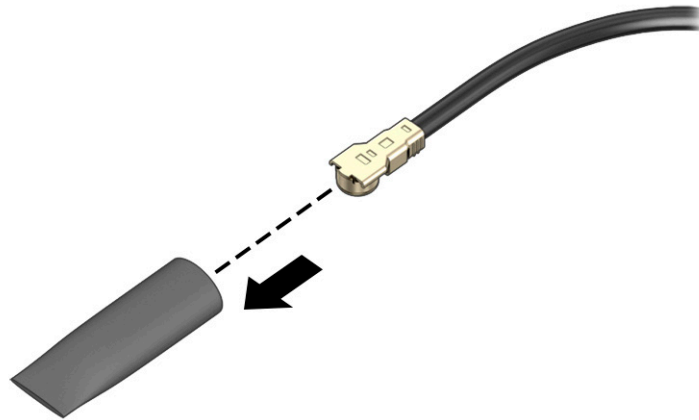

Reverse this procedure to install the WWAN module.

## RTC battery

To remove the RTC battery, use this procedure and illustration.

**Table 6-4** RTC battery description and part number

Description	Spare part number
RTC battery	L13694-001

Before removing the RTC battery, follow these steps:

1. Prepare the computer for disassembly (see [Preparation for disassembly on page 43](#)).
2. Remove the bottom cover (see [Bottom cover on page 35](#)).
3. Remove the battery (see [Battery on page 43](#)).

Remove the RTC battery:

1. Disconnect the battery cable from the system board (1).
2. Use a tool to release the battery from the computer (2).

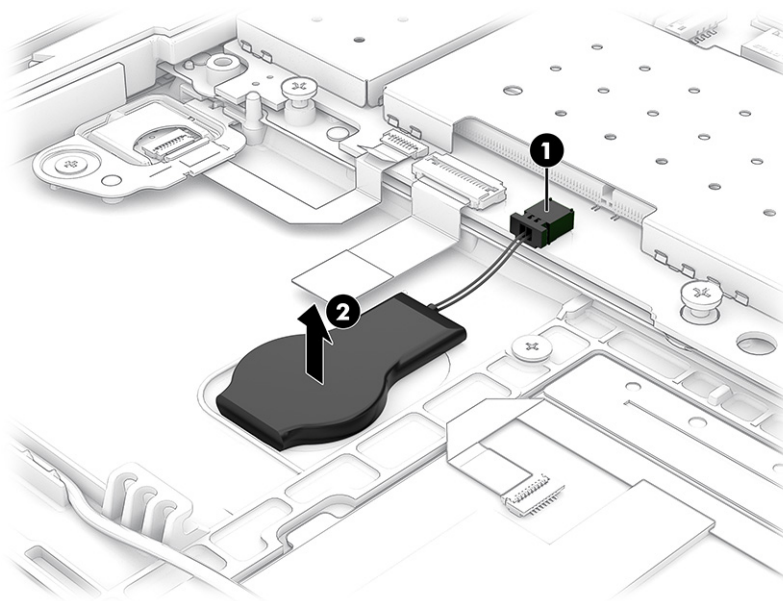

Reverse this procedure to install the RTC battery.

## Speakers

To remove the speakers, use this procedure and illustration.

**Table 6-5** Speaker description and part number

Description	Spare part number
Speaker Kit	M30648-001

Before removing the speakers, follow these steps:

1. Prepare the computer for disassembly (see [Preparation for disassembly on page 43](#)).

2. Remove the bottom cover (see [Bottom cover on page 35](#)).
3. Remove the battery (see [Battery on page 43](#)).

Remove the speakers:

1. Disconnect the speaker cable from the system board (1).
2. Remove the speakers from the computer (2) and remove the cable between the speakers from the clips along the bottom of the computer (3).

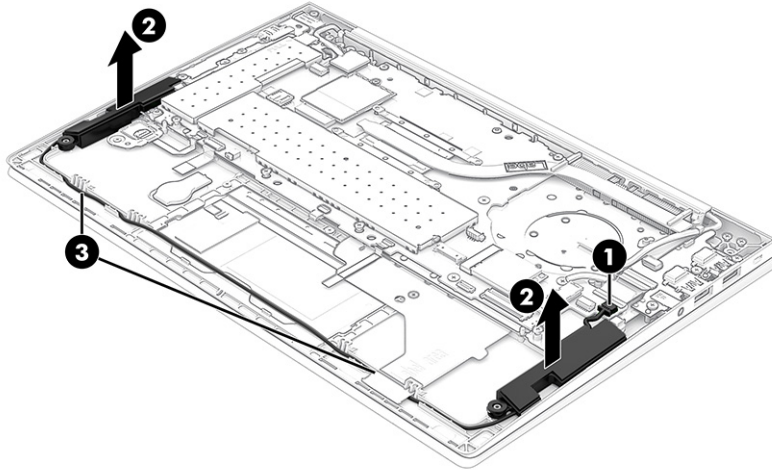

Reverse this procedure to install the speakers.

## Power connector cable

To remove the power connector cable, use this procedure and illustration.

**Table 6-6** Power connector cable description and part number

Description	Spare part number
Power connector cable	M15626-001

Before removing the power connector cable, follow these steps:

1. Prepare the computer for disassembly (see [Preparation for disassembly on page 43](#)).
2. Remove the bottom cover (see [Bottom cover on page 35](#)).
3. Disconnect the battery cable from the system board (see [Battery on page 43](#)).

Remove the power connector cable:

1. Disconnect the cable from the system board (1), and then remove the cable from the clip (2).
2. Remove the Phillips M2.0 × 4.0 screw (3) that secures the power connector cable to the computer.

3. Remove the power connector cable from the computer (4).

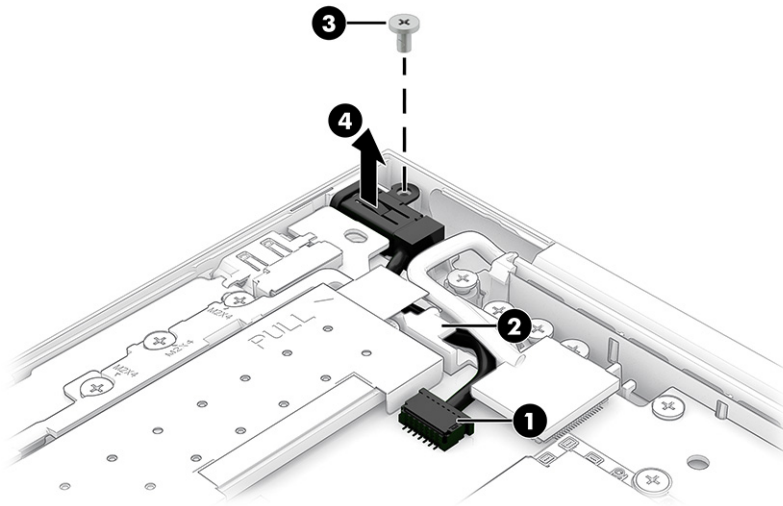

Reverse this procedure to install the power connector cable.

## USB board

To remove the USB board, use this procedure and illustration.

**Table 6-7** USB board description and part number

Description	Spare part number
USB board	M36398-001
USB board cables (included in Cable Kit)	M30646-001

Before removing the USB board, follow these steps:

1. Prepare the computer for disassembly (see [Preparation for disassembly on page 43](#)).
2. Remove the bottom cover (see [Bottom cover on page 35](#)).
3. Disconnect the battery cable from the system board (see [Battery on page 43](#)).

Remove the USB board:

1. Disconnect the smaller cable from the USB board (1).
2. Disconnect the larger cable from the ZIF connector on the USB board (2).
3. Remove the three Phillips M2.0 × 4.0 screws (3).

4. Lift the back of the board up, and then remove board from computer (4).

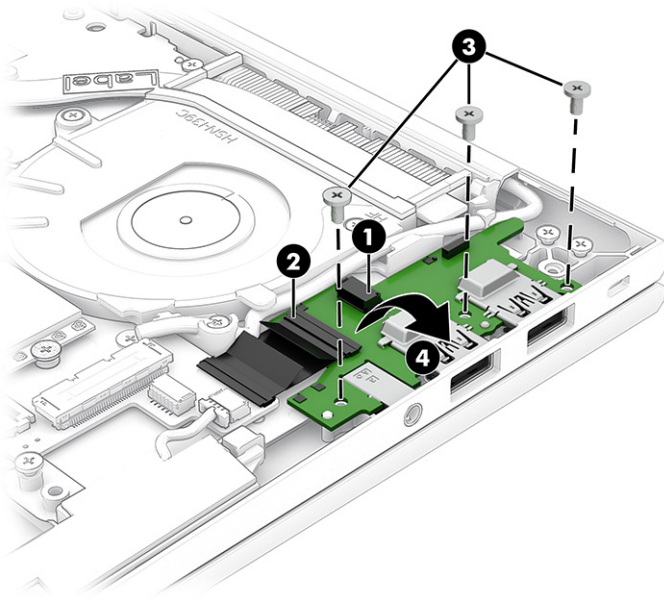

Reverse this procedure to install the USB board.

## Fingerprint reader board

To remove the fingerprint reader board, use this procedure and illustration.

**Table 6-8** Fingerprint reader board description and part number

Description	Spare part number
Fingerprint reader board	M30665-001
Fingerprint reader board cable (included in Cable Kit)	M30646-001
Fingerprint reader board bracket	M36397-001

Before removing the fingerprint reader board, follow these steps:

1. Prepare the computer for disassembly (see [Preparation for disassembly on page 43](#)).
2. Remove the bottom cover (see [Bottom cover on page 35](#)).
3. Remove the battery (see [Battery on page 43](#)).

Remove the fingerprint reader board:

1. Remove the Phillips M2.0 × 2.0 screw (1) that secures the fingerprint reader bracket to the computer, and then remove the bracket (2).
2. Disconnect the cable from the ZIF connector on the fingerprint reader board (3).

3. Remove the fingerprint reader board from the computer (4).

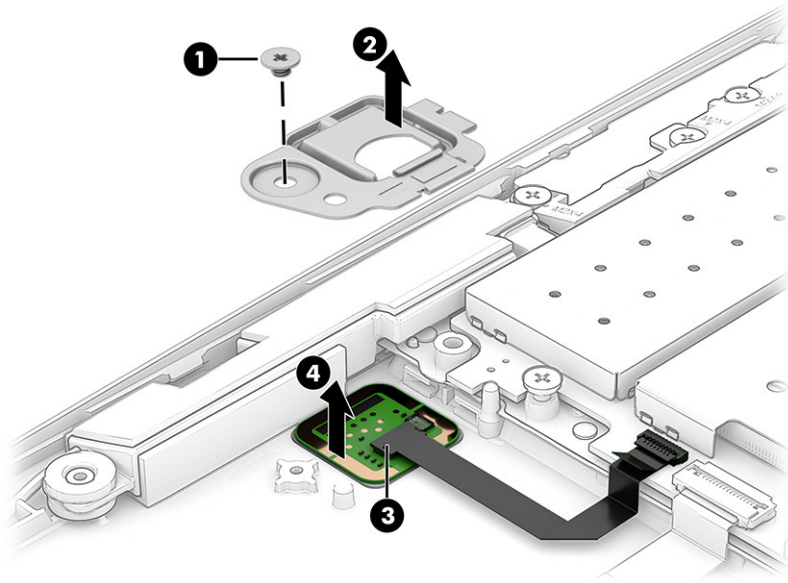

Reverse this procedure to install the fingerprint reader board.

## Touchpad

To remove the touchpad, use this procedure and illustration.

**Table 6-9** Touchpad description and part number

Description	Spare part number
Touchpad (not available as a spare part component)	
Touchpad cable (included in Cable Kit)	M30646-001

Before removing the touchpad, follow these steps:

1. Prepare the computer for disassembly (see [Preparation for disassembly on page 43](#)).
2. Remove the bottom cover (see [Bottom cover on page 35](#)).
3. Remove the battery (see [Battery on page 43](#)).

Remove the touchpad:

1. Disconnect the cable from the ZIF connector on the touchpad (1).
2. Remove the three Phillips M2.0 × 2.0 screws (2) that secure the touchpad to the computer.

3. Lift the top of the touchpad, and then pull it away from the bottom of the computer to remove it (3).

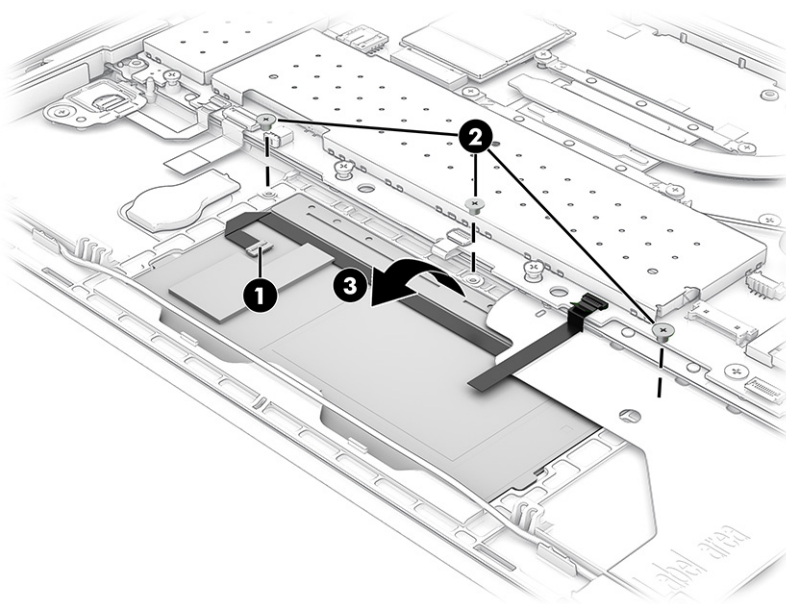

Reverse this procedure to install the touchpad.

## Fan

To remove the fan, use this procedure and illustration.

**Table 6-10** Fan description and part number

Description	Spare part number
Fan	M30650-001

Before removing the fan, follow these steps:

1. Prepare the computer for disassembly (see [Preparation for disassembly on page 43](#)).
2. Remove the bottom cover (see [Bottom cover on page 35](#)).
3. Disconnect the battery cable from the system board (see [Battery on page 43](#)).

Remove the fan:

1. Remove the cables from the clips on the side of the fan (1).
2. Disconnect the fan cable from the system board (2).

- Loosen the three Phillips captive screws (3) that secure the fan to the computer, and then remove the fan from the computer (4).

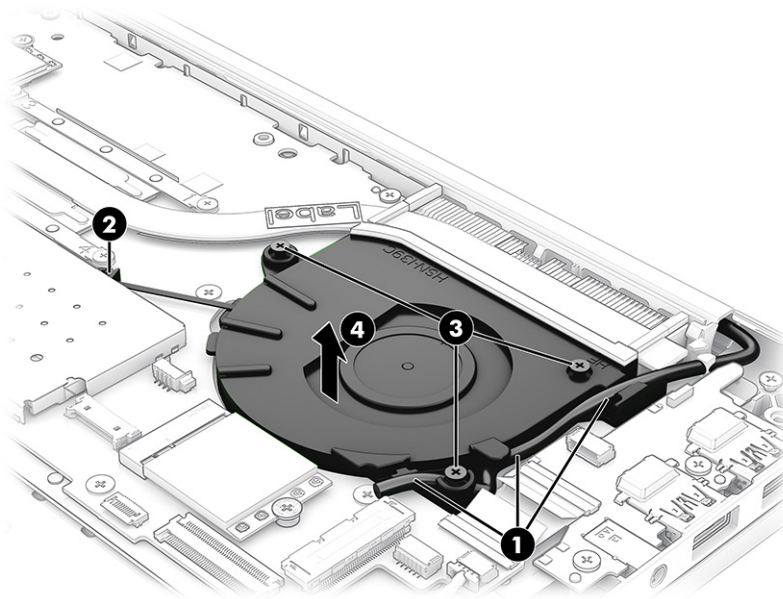

Reverse this procedure to install the fan.

## Heat sink

To remove the heat sink, use these procedures and illustrations.

**Table 6-11** Heat sink descriptions and part numbers

Description	Spare part number
Heat sink	M30651-001

Before removing the heat sink, follow these steps:

- Prepare the computer for disassembly (see [Preparation for disassembly on page 43](#)).
- Remove the bottom cover (see [Bottom cover on page 35](#)).
- Disconnect the battery cable from the system board (see [Battery on page 43](#)).

Remove the heat sink:

- In the order indicated on the heat sink, loosen the four captive Phillips screws (1) that secure the heat sink to the computer.

2. Remove the heat sink from the computer (2).

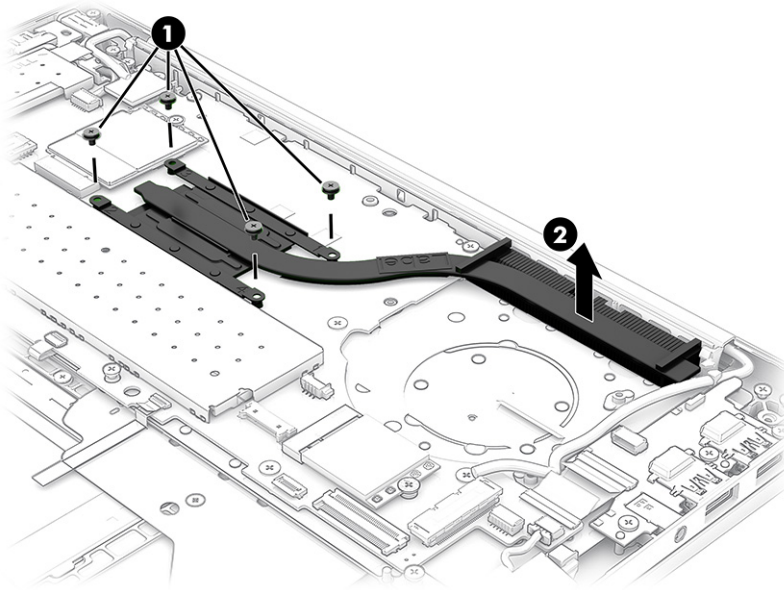

3. Thoroughly clean the thermal material from the surfaces of the heat sink and the system board components each time the heat sink is removed. Replacement thermal material is included with the heat sink and system board spare part kits. The following illustration shows the replacement thermal material locations.

Thermal paste is used on the heat sink (1) and associated system board component (2).

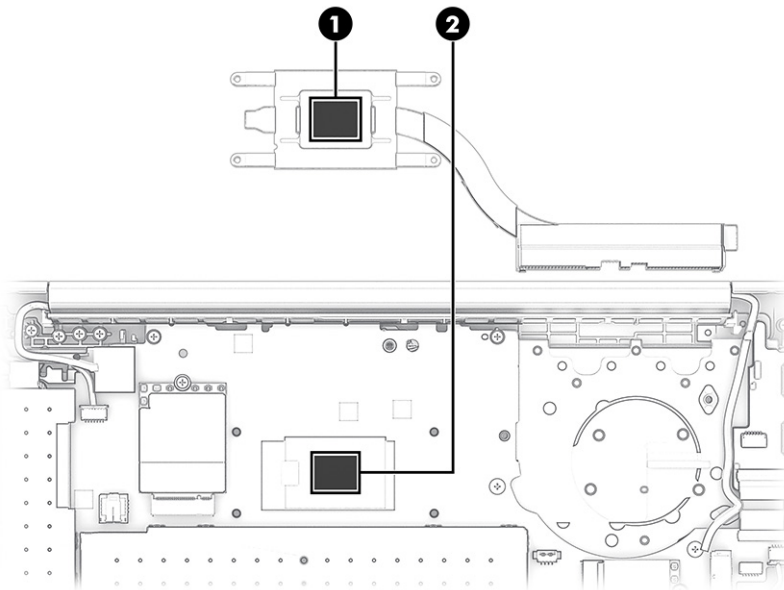

Reverse this procedure to install the heat sink.

## System board

To remove the system board, use these procedures and illustrations.

**Table 6-12 System board descriptions and part numbers**

Description	Spare part number
System board (includes integrated processor, graphics subsystem with UMA memory, replacement thermal material, and the Google Chrome operating system):	
Equipped with an AMD Ryzen 7 PRO 5850U processor for use on computer models with WWAN capability	M52743-001
Equipped with an AMD Ryzen 7 PRO 5850U processor for use on computer models without WWAN capability	M52742-001
Equipped with an AMD Ryzen 7 PRO 5800U processor for use on computer models with WWAN capability	M52741-001
Equipped with an AMD Ryzen 7 PRO 5800U processor for use on computer models without WWAN capability	M52740-001
Equipped with an AMD Ryzen 5 PRO 5650U processor for use on computer models with WWAN capability	M52739-001
Equipped with an AMD Ryzen 5 PRO 5650U processor for use on computer models without WWAN capability	M52738-001
Equipped with an AMD Ryzen 5 PRO 5600U processor for use on computer models with WWAN capability	M52737-001
Equipped with an AMD Ryzen 5 PRO 5600U processor for use on computer models without WWAN capability	M52736-001
Equipped with an AMD Ryzen 3 PRO 5400U processor for use on computer models with WWAN capability	M52735-001
Equipped with an AMD Ryzen 3 PRO 5400U processor for use on computer models without WWAN capability	M52734-001

Before removing the system board, follow these steps:

1. Prepare the computer for disassembly (see [Preparation for disassembly on page 43](#)).
2. Remove the bottom cover (see [Bottom cover on page 35](#)).
3. Remove the battery (see [Battery on page 43](#)).
4. Remove the fan (see [Fan on page 54](#)).

When you replace the system board, be sure to remove the following components (as applicable) from the defective system board and install them on the replacement system board:

- Memory modules (see [Memory modules on page 37](#)).
- Solid-state drive (see [Solid-state drive on page 40](#)).
- WLAN module (see [WLAN module on page 45](#)).
- WWAN module (see [WWAN module on page 46](#)).
- Heat sink (see [Heat sink on page 55](#)).

Remove the system board:

1. Disconnect the following cables from the system board:
  - Power connector cable **(1)**
  - Camera cable **(2)**
  - Antenna cables from the WWAN module (select products only) **(3)**
  - Larger USB cable from the USB board (ZIF) **(4)**

- Small USB cable from the system board (5)
- Speaker cable (6)
- Display cable (7)
- Antenna cables from the WLAN module (8)
- Keyboard cable (ZIF) (9)
- Touchpad cable (ZIF) (10)
- Keyboard backlight cable (ZIF) (select products only) (11)
- RTC battery cable (12)
- Fingerprint reader cable (ZIF) (select products only) (13)

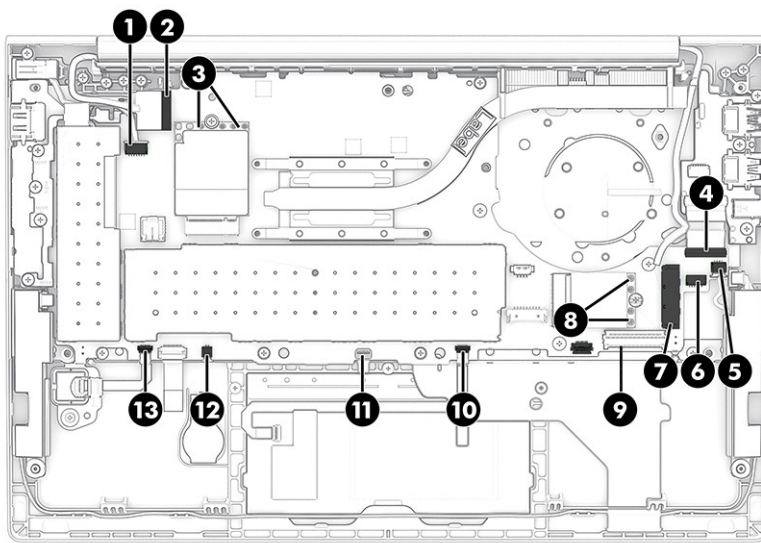

2. Remove the cables from the clip in the bracket (1).
3. Remove the four Phillips M2.0 × 4.0 screws (2) that secure the bracket to the system board, and then remove the bracket (3).

The plastic bracket is available in the Plastics Kit as spare part number M30663-001.

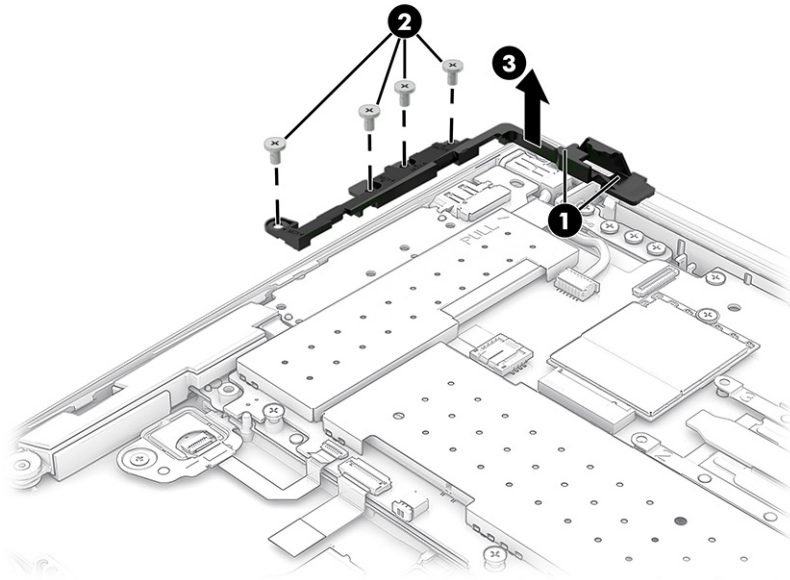

4. Remove the two Phillips M2.0 × 4.0 screws (1) and the three Phillips M2.0 × 2.0 screws (2) that secure the system board to the computer.

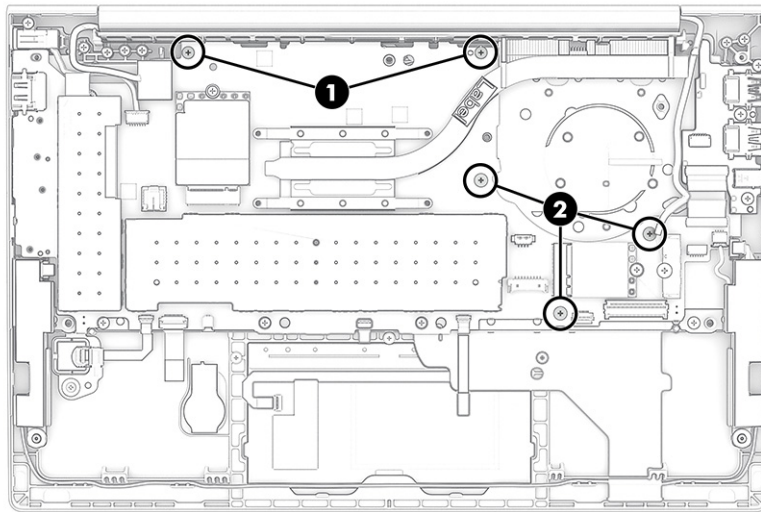

5. Remove the SIM card insert from the computer (1).

- Lift the side of the system board upward (2), and then pull the system board away from the connectors on the side of the computer to remove it (3).

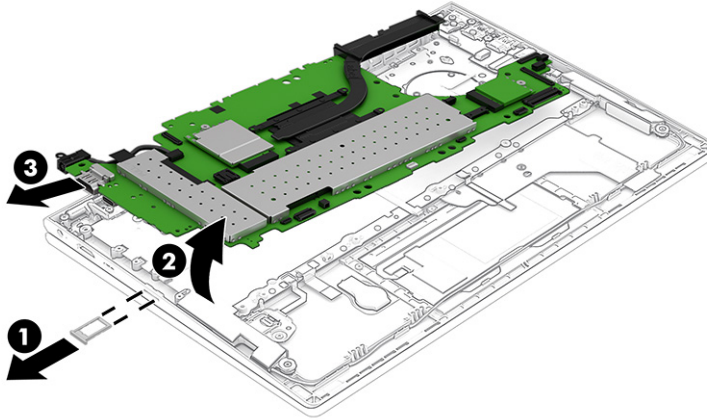

---

 **NOTE:** When replacing the system board, be sure to leave the RTC battery installed on the old system board.

---

Reverse this procedure to install the system board.

## Display assembly

To remove and disassemble the display assembly, use these procedures and illustrations.

Full hinge-up displays are not available as spare parts. Spare parts for displays are available only at the subcomponent level.

Before removing the display panel, follow these steps:

- Prepare the computer for disassembly (see [Preparation for disassembly on page 43](#)).
- Remove the bottom cover (see [Bottom cover on page 35](#)).
- Disconnect the battery cable from the system board (see [Battery on page 43](#)).
- Remove the power connector cable (see [Power connector cable on page 50](#)).

Remove the display assembly:

- Disconnect the camera cable (1) and the antenna cables from the WWAN module (2).

2. Disconnect the display cable (3) and the antenna cables from the WLAN module (4).

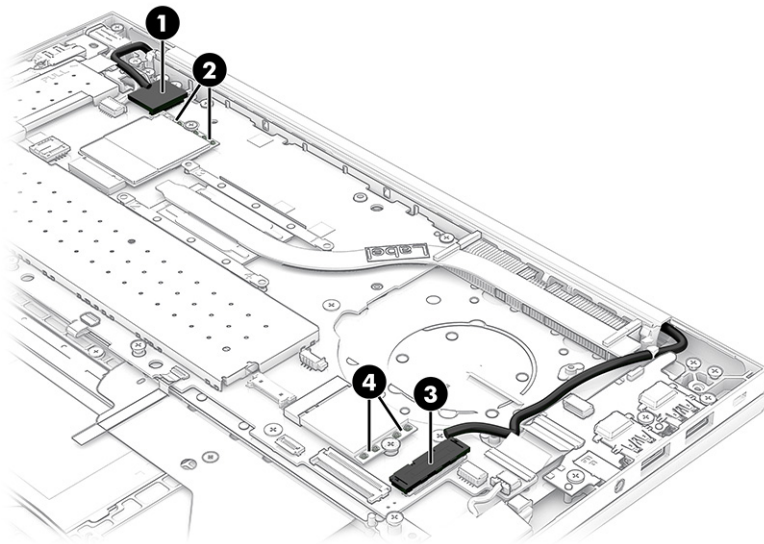

3. Remove the six Phillips M2.5 × 4.0 screws that secure the display assembly to the computer.

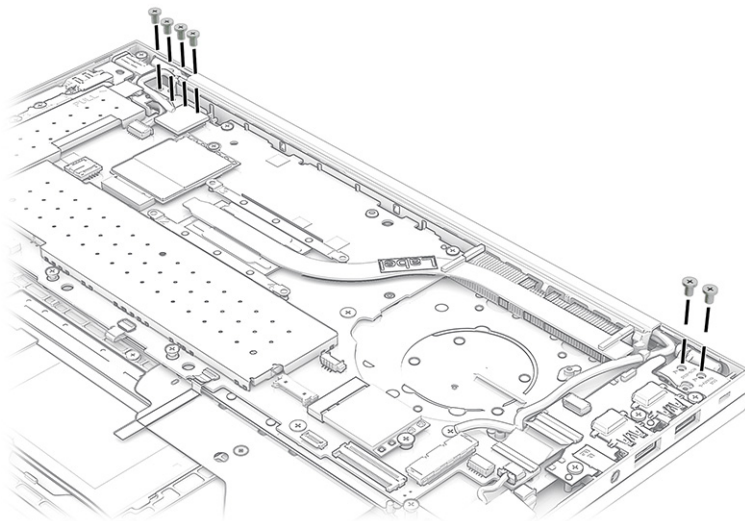

4. Rotate the display to open the hinges (1).

5. Separate the display assembly from the computer (2).

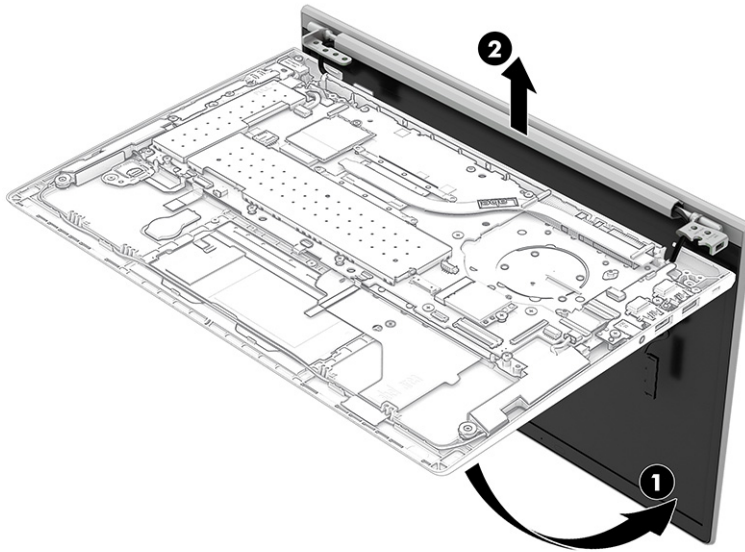

6. If you need to replace display assembly subcomponents:
  - a. Flex the top (1), the left and right sides (2), and then the bottom of the bezel (3) to release it.
  - b. Remove the bezel from the display (4).

The display bezel is available using the following spare part numbers:

- M30658-001: For use in models with an IR camera and ambient light sensor
- M30657-001: For use in models with an IR camera
- M30656-001: For use in models with an RGB camera
- M30659-001: For use in models with a microphone module (no camera)

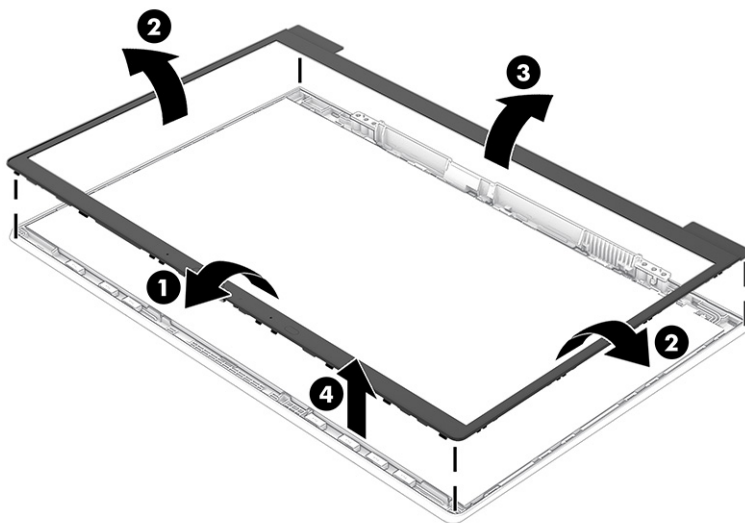

7. If you need to remove the display panel:

 **NOTE:** You do not need to remove the hinge cover or hinges to remove the display panel.

- a. Multiple alignment tools are included with the replacement panel. Check the fit of the various alignment tools on the display assembly. Make note of the best fitting alignment tool to use when replacing the display panel.
- b. The display panel is secured to the display enclosure with tape that is installed under the left and right sides of the panel. To remove the panel, use tweezers to grasp the end of the tape (1). While turning the tweezers, wrap the tape around the tweezers (2) as you continue to pull the tape out from behind the display panel (3). You must pull the tape multiple times before it is completely removed.
- c. Rotate the display panel over and place it next to the display enclosure (4).

The display panel is available using the following spare part numbers:

M52479-001: For use on computer models with display panels with privacy filter

M52748-001: For use on computer models with display panels with 400 nit brightness

M52747-001: For use on computer models with display panels with 250 nit brightness

The LCD Support Kit is available using spare part number M33161-001 and includes double-sided tape and foam sponge.

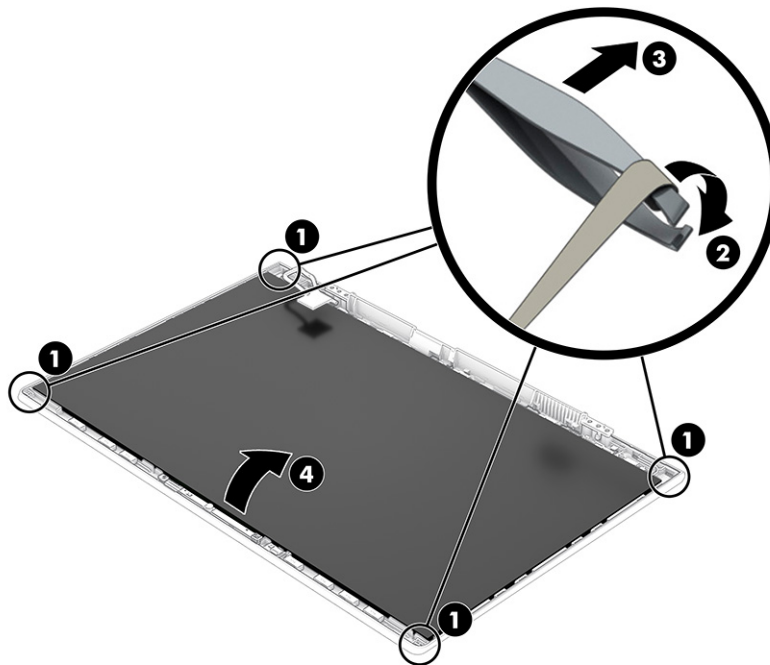

- d. Place the display panel next to the display enclosure (1).
- e. Lift the tape from the connector on the display panel (2), rotate the locking lever (3), and then disconnect the cable from the panel (4).

- f. Remove the panel (5).

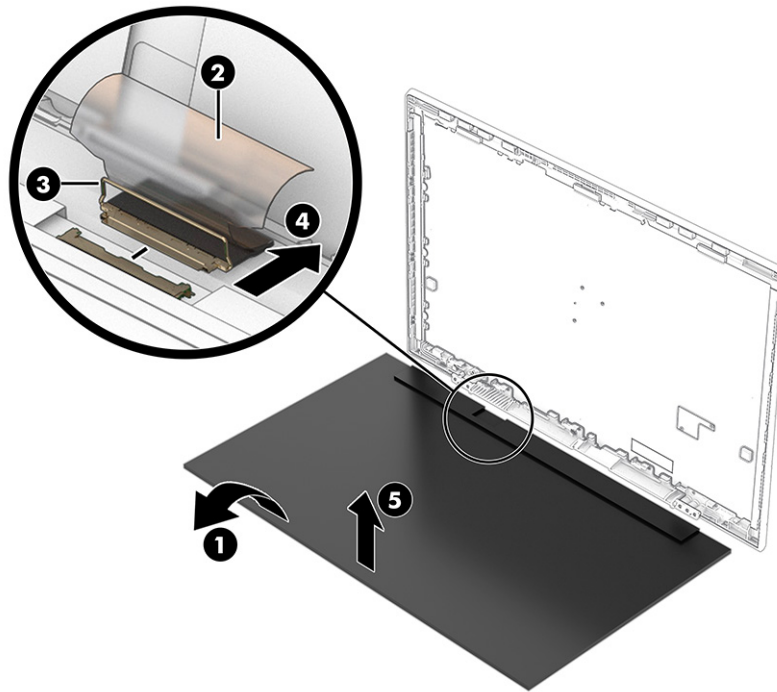

8. When replacing the display panel, follow these steps:

 **IMPORTANT:** Before installing the display panel, be sure to install the display cable on the back of the panel.

- a. Peel the protective layer from the bottom of the adhesive strips (1).
- b. Starting near the bottom of the inside of the display back cover (2), install the adhesive strips on both the left and right sides by aligning them with the groove on the edge of cover (3).
- c. Peel the protective layer from the top of the adhesive strips (4).
- d. Install the previously selected alignment tools onto the upper left and right corners of the display rear cover (5).
- e. Insert the top of the panel into the top of the display rear cover (6), and then rotate the panel into place (7). Be sure that the upper corners of the panel are positioned up against the insides of the alignment tools.

The double-sided adhesive strips are available using spare part number M33161-001.

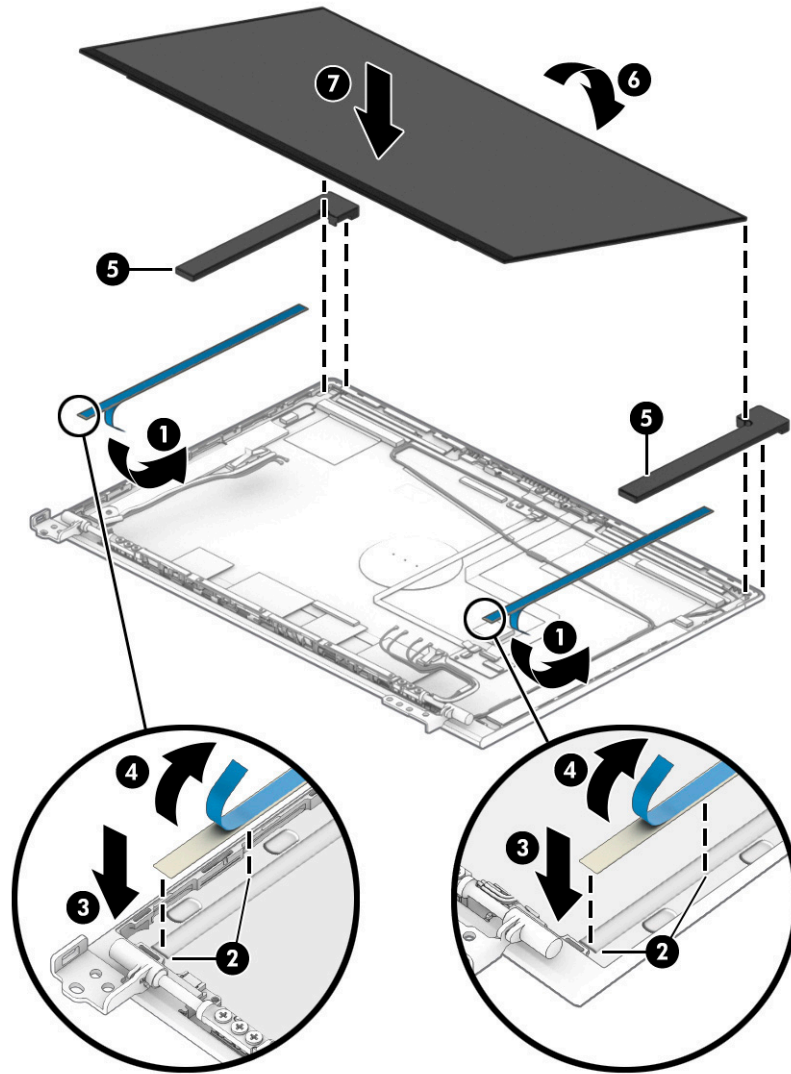

- f. Remove the alignment tool.
- g. Replace the bezel by pressing along the bottom, sides, and then top of the bezel to snap it into place.

- h. Install temporary rubber spacer strips on the left and right sides of the bezel (1), and then close the display (2).

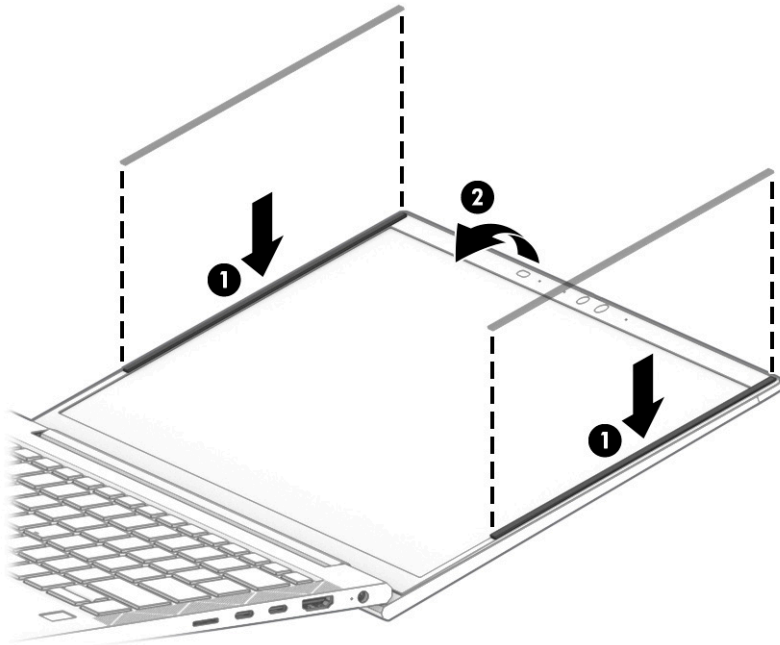

- i. Position the computer upside down on a table.  
j. Leave the computer upside down on the table for 20 minutes to allow the adhesive to set.



- k. Position the computer upright on a table.

- l. Leave the computer upright on the table for 10 minutes to be sure that the panel sits correctly in the display.

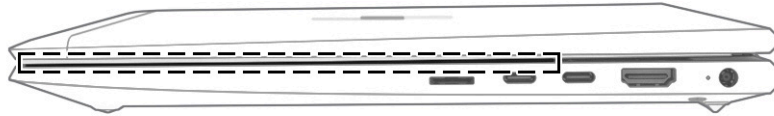

- m. Open the display and remove rubber spacer strips.
  - n. Replace the hinge cover by positioning the cover over the bottom of the display, rotating the cover upward, sliding it to the left, and then replacing the screw.
9. If you need to remove the hinge cover from the display enclosure:
- a. Remove the Phillips M1.2 × 3.0 screw **(1)** that secures the hinge cover to the display.
  - b. Slide the hinge cover toward the right **(2)**.
  - c. Rotate the bottom of the hinge cover up, and then remove it from the display **(3)**.
  - d. Note the location of all cables that are hidden by the hinge cover so that you can be sure to properly route the cables during reassembly.

The hinge cover is available in the Plastics Kit, spare part number M30663-001.

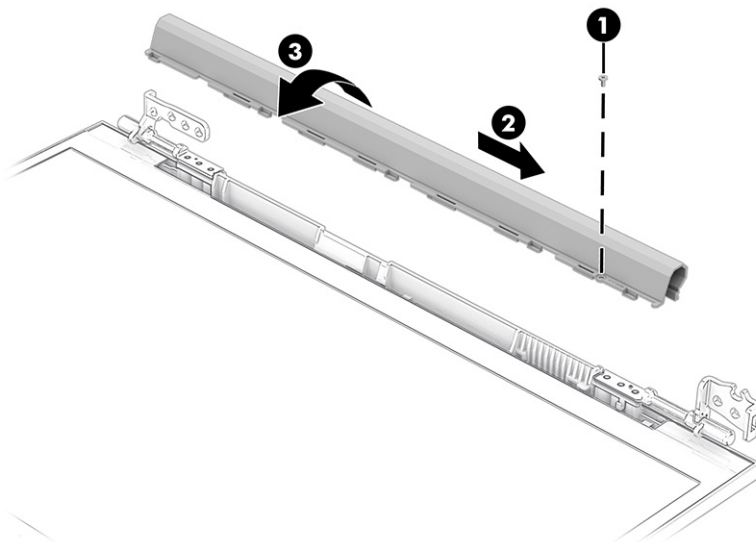

10. If you need to remove the hinges from the display enclosure:
- a. Remove the three Phillips M2.5 × 10.0 screws **(1)** from each hinge.

- b. Remove the hinges from the display (2).

The hinges are available in the Hinge Kit, spare part number M30666-001.

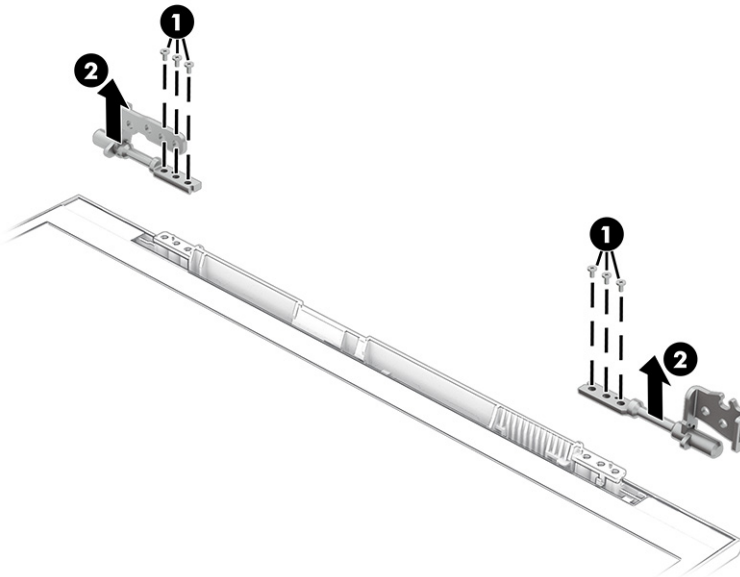

- 11. When installing the display hinges, use the following illustration to determine proper cable routing. The WWAN antenna cables and display cable route through the right hinge (1). The WLAN antenna cables and display cable route through the left hinge (2).

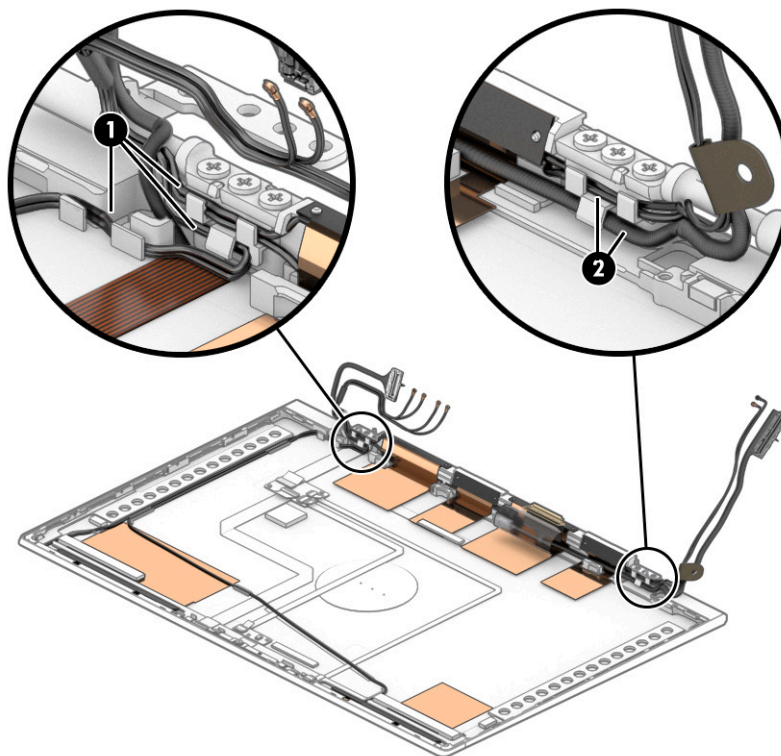

- 12. If you need to remove the hub board from the display:

- a. Disconnect the display cable from the ZIF connector (1) on the hub board.

- b. Disconnect the camera cable from the ZIF connector (2) on the hub board.
- c. Disconnect the smaller cables from the reverse ZIF connectors on the hub board (3) (4).
- d. Use a tool (5) to release the board from the display rear cover (6).

The hub board is available using spare part numbers M30673-001 (for use on computer models equipped with an IR camera) and M30672-001 (for use on computer models equipped with an RGB camera or microphone module).

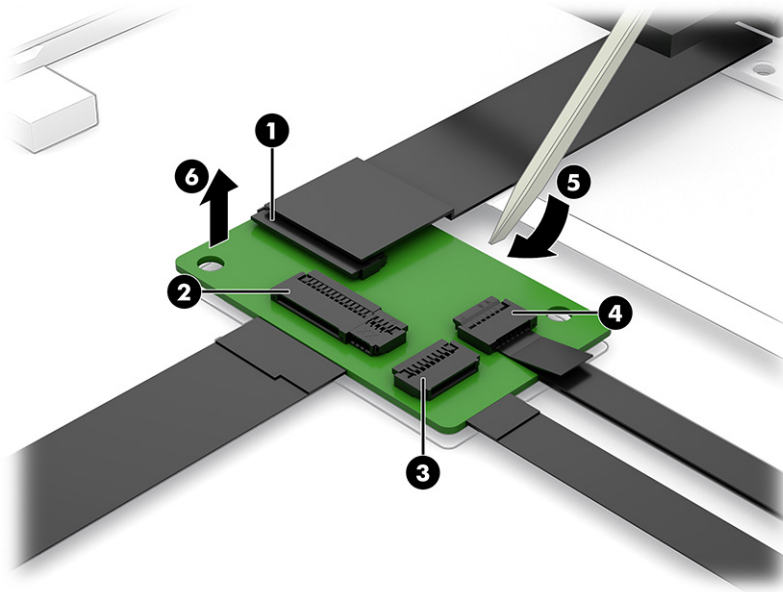

13. If you need to remove the ambient light sensor from the display, disconnect the cable from the reverse ZIF connector on the board (1), and then use a tool (2) to release the sensor from the computer (3).

The ambient light sensor is available using spare part number M30669-001.

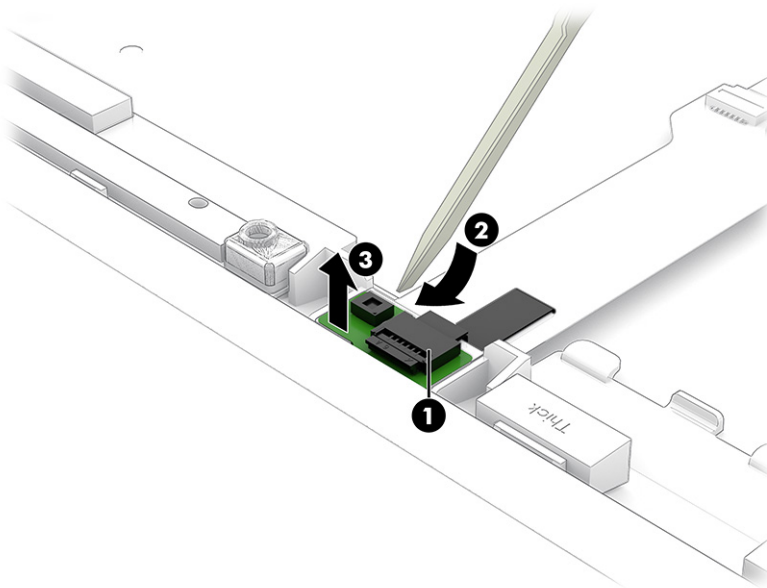

14. If you need to remove the second ambient light sensor from the display, disconnect the cables from the ZIF connectors on the board (1), and then remove the sensor from the computer (2).

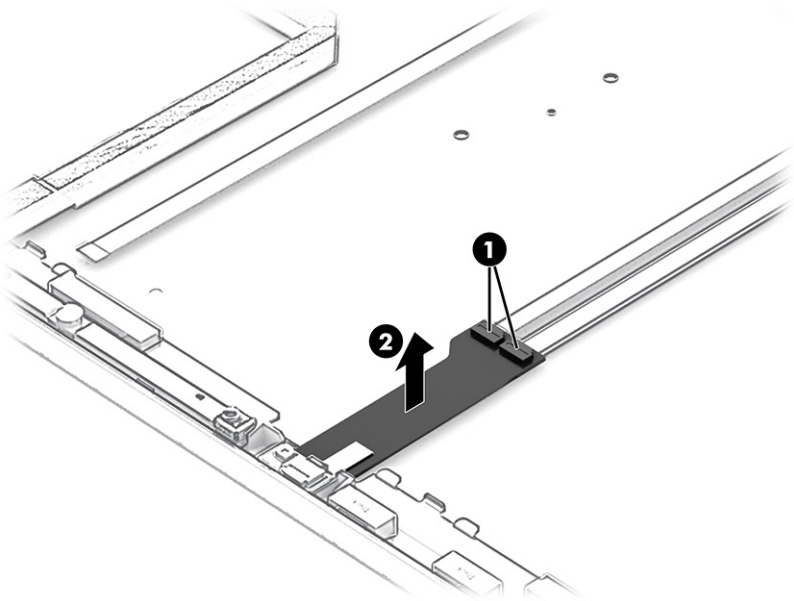

15. If you need to remove the camera module:

- ▲ Use a tool to lift up evenly across the module and peel the module up from the display back cover (1), and then disconnect the cable from the reverse ZIF connector on the module (2). The camera module is available using spare part numbers M30660-001 (on computer models equipped with an HD camera) and M30661-001 (on computer models equipped with an IR camera). The microphone module is available using spare part number M30671-001.



**NOTE:** For installation, note that the cable routes under the camera module before it connects to the module.

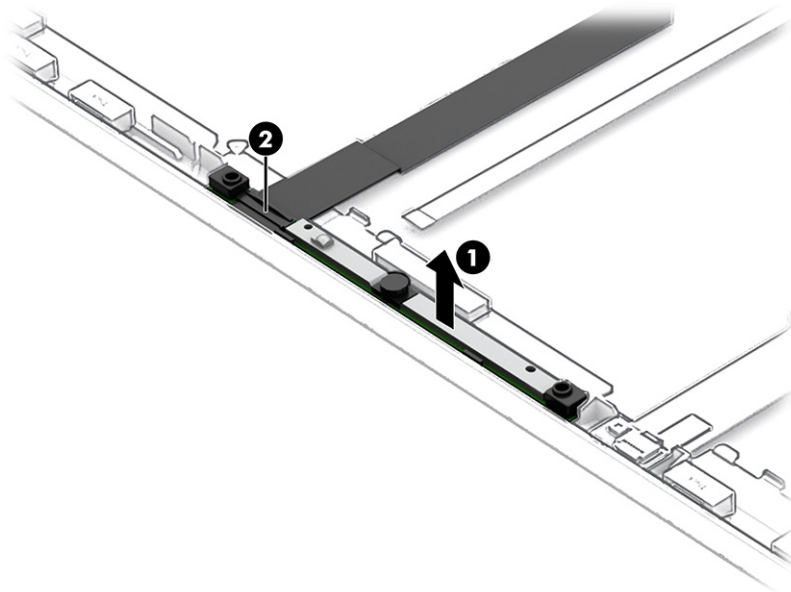

16. If you need to remove the display cable, disconnect the cable from the ZIF connector on the hub board (1), remove the cable from the clips at the bottom of the display back cover (2), and then remove the cable (3).

The display panel cable is available using spare part number M30647-001.

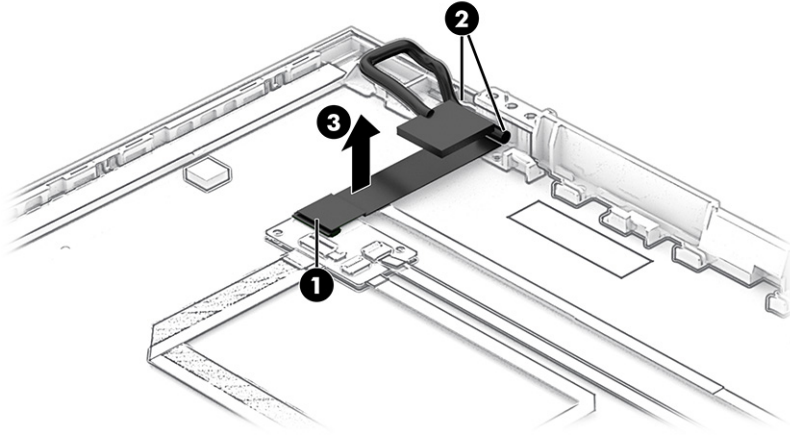

17. If you need to remove the camera cable, disconnect the cable from the ZIF connector on the hub board, and then peel the cable off the inside of the display back cover to remove it.

The camera cable is available in the Cable Kit, spare part number M30646-001.

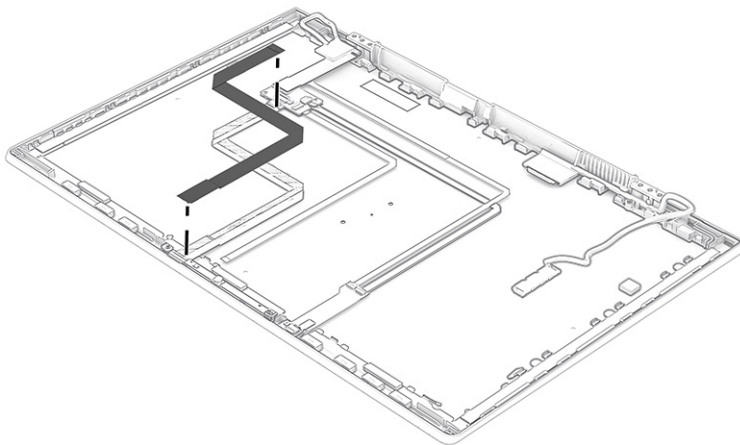

18. If you need to remove the WLAN antenna cables, remove the cables from the clips at the bottom and side of the cover (1), and then peel the antennas off the inside of the display back cover (2).

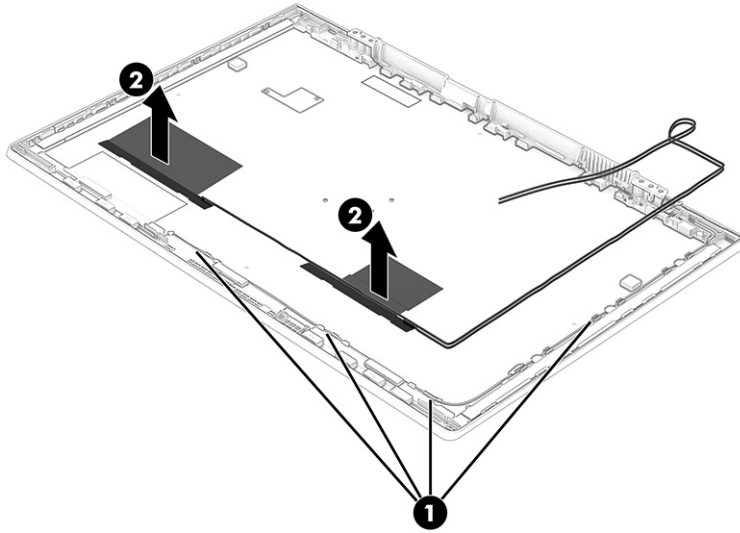

19. If you need to remove the WWAN antenna cables, remove the cables from the clips along the edges of the display back cover (1), peel the antennas off the inside of the cover (2), and then remove the antennas and cables (3).

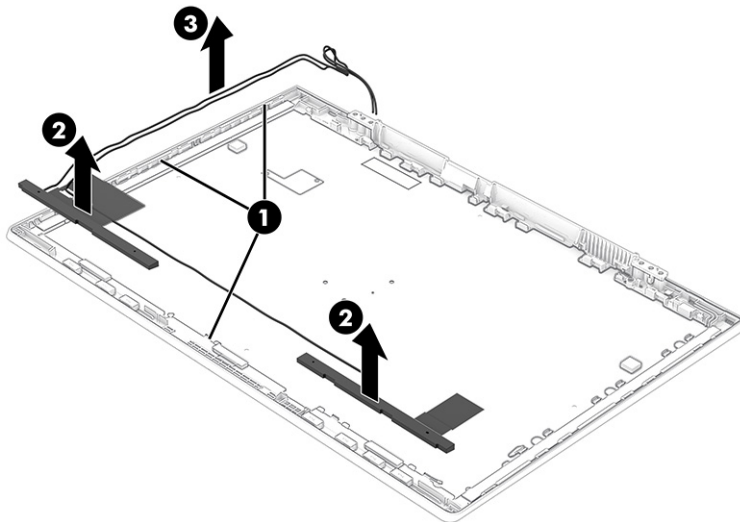

20. If you need to remove the ambient light sensor cable, disconnect the cable from the ZIF connectors on the ambient light sensor board (1) and hub board (2), and then peel the cable off the inside of the display back cover to remove it (3).

The ambient light sensor cable is available in the Cable Kit, spare part number M30646-001.

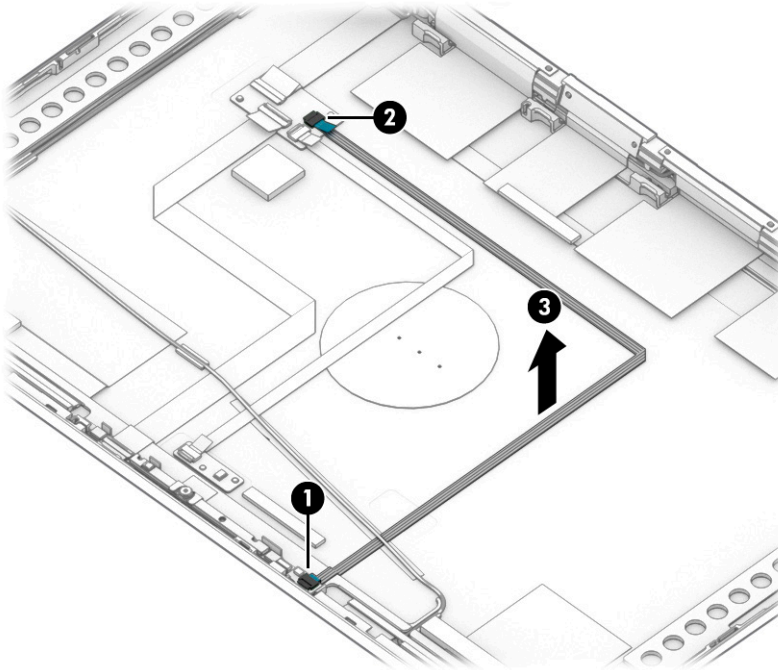

21. If you need to remove the second ambient light sensor cables, disconnect the cable from the ZIF connectors on the second ambient light sensor (1) and hub board (2), and then peel the cables off the inside of the display back cover to remove them (3).

The second ambient light sensor cable is available in the Cable Kit, spare part number M30646-001.

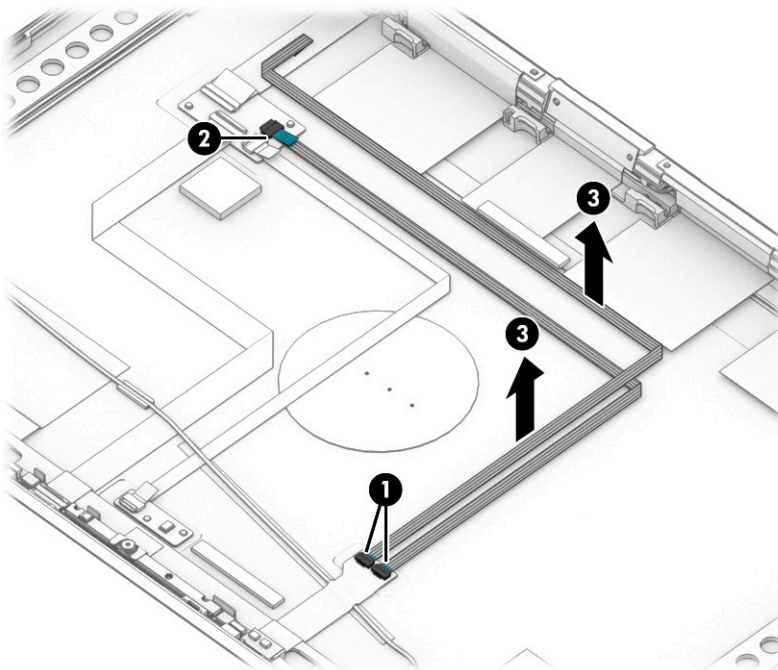

The display back cover is available using the following spare part numbers:

M30653-001: Models with WWAN, thin

M30654-001: Models with WLAN, thick

M30655-001: Models with WLAN, thin

Reverse this procedure to reassemble and replace the display assembly.

## Keyboard with top cover

The top cover with keyboard remains after removing all other spare parts from the computer. In this section, the first table provides the main spare part number for the top cover/keyboards. The second table provides the country codes.

**Table 6-13 Top cover/keyboard spare part descriptions and spare part numbers**

For use in country or region	Spare part number	For use in country or region	Spare part number
Top cover/keyboard with backlight and privacy filter (includes backlight cable and keyboard cable):			
Belgium	M30683-A41	Northern Africa	M30683-FP1
Brazil	M30683-201	Norway	M30683-091
Bulgaria	M30683-261	Portugal	M30683-131
Canada	M30683-DB1	Romania	M30683-271
Czech Republic and Slovenia	M30683-FL1	Russia	M30683-251
Denmark	M30683-081	Saudi Arabia	M30683-171
Denmark, Finland, and Norway	M30683-DH1	Slovakia	M30683-BA1
France	M30683-051	South Korea	M30683-AD1
Germany	M30683-041	Spain	M30683-071
Greece	M30683-151	Sweden and Finland	M30683-B71
Hungary	M30683-211	Switzerland	M30683-BG1
Iceland	M30683-DD1	Taiwan	M30683-AB1
India	M30683-D61	Thailand	M30683-281
Israel	M30683-BB1	Turkey	M30683-141
Italy	M30683-061	Ukraine	M30683-BD1
Japan	M30683-291	United Kingdom	M30683-031
Latin America	M30683-161	United States	M30683-001
The Netherlands	M30683-B31		
Top cover/keyboard with backlight (includes backlight cable and keyboard cable):			
Belgium	M30681-A41	Northern Africa	M30681-FP1
Brazil	M30681-201	Norway	M30681-091
Bulgaria	M30681-261	Portugal	M30681-131
Canada	M30681-DB1	Romania	M30681-271
Czech Republic and Slovenia	M30681-FL1	Russia	M30681-251
Denmark	M30681-081	Saudi Arabia	M30681-171
Denmark, Finland, and Norway	M30681-DH1	Slovakia	M30681-BA1
France	M30681-051	South Korea	M30681-AD1
Germany	M30681-041	Spain	M30681-071

**Table 6-13 Top cover/keyboard spare part descriptions and spare part numbers (continued)**

For use in country or region	Spare part number	For use in country or region	Spare part number
Greece	M30681-151	Sweden and Finland	M30681-B71
Hungary	M30681-211	Switzerland	M30681-BG1
Iceland	M30681-DD1	Taiwan	M30681-AB1
India	M30681-D61	Thailand	M30681-281
Israel	M30681-BB1	Turkey	M30681-141
Italy	M30681-061	Ukraine	M30681-BD1
Japan	M30681-291	United Kingdom	M30681-031
Latin America	M30681-161	United States	M30681-001
The Netherlands	M30681-B31		
Top cover/keyboard (includes keyboard cable):			
Belgium	M30682-A41	Northern Africa	M30682-FP1
Brazil	M30682-201	Norway	M30682-091
Bulgaria	M30682-261	Portugal	M30682-131
Canada	M30682-DB1	Romania	M30682-271
Czech Republic and Slovenia	M30682-FL1	Russia	M30682-251
Denmark	M30682-081	Saudi Arabia	M30682-171
Denmark, Finland, and Norway	M30682-DH1	Slovakia	M30682-BA1
France	M30682-051	South Korea	M30682-AD1
Germany	M30682-041	Spain	M30682-071
Greece	M30682-151	Sweden and Finland	M30682-B71
Hungary	M30682-211	Switzerland	M30682-BG1
Iceland	M30682-DD1	Taiwan	M30682-AB1
India	M30682-D61	Thailand	M30682-281
Israel	M30682-BB1	Turkey	M30682-141
Italy	M30682-061	Ukraine	M30682-BD1
Japan	M30682-291	United Kingdom	M30682-031
Latin America	M30682-161	United States	M30682-001
The Netherlands	M30682-B31		



---

# 7 Backing up, restoring, and recovering

You can use Windows tools or HP software to back up your information, create a restore point, reset your computer, create recovery media, or restore your computer to its factory state. Performing these standard procedures can return your computer to a working state faster.

---

 **IMPORTANT:** If you will be performing recovery procedures on a tablet, the tablet battery must be at least 70% charged before you start the recovery process.

 **IMPORTANT:** For a tablet with a detachable keyboard, connect the tablet to the keyboard base before beginning any recovery process.

---

## Backing up information and creating recovery media

These methods of creating recovery media and backups are available on select products only.

### Using Windows tools for backing up

HP recommends that you back up your information immediately after initial setup. You can do this task either using Windows Backup locally with an external USB drive or using online tools.

---

 **IMPORTANT:** Windows is the only option that allows you to back up your personal information. Schedule regular backups to avoid information loss.

 **NOTE:** If computer storage is 32 GB or less, Microsoft® System Restore is disabled by default.

---

### Using the HP Cloud Recovery Download Tool to create recovery media (select products only)

You can use the HP Cloud Recovery Download Tool to create HP Recovery media on a bootable USB flash drive.

For details:

▲ Go to <http://www.hp.com/support>, search for HP Cloud Recovery, and then select the result that matches the type of computer that you have.

---

 **NOTE:** If you cannot create recovery media yourself, contact support to obtain recovery discs. Go to <http://www.hp.com/support>, select your country or region, and then follow the on-screen instructions.

 **IMPORTANT:** HP recommends that you follow the [Restoring and recovery methods on page 78](#) to restore your computer before you obtain and use the HP recovery discs. Using a recent backup can return your machine

to a working state sooner than using the HP recovery discs. After the system is restored, reinstalling all the operating system software released since your initial purchase can be a lengthy process.

---

## Restoring and recovering your system

You have several tools available to recover your system both within and outside of Windows if the desktop cannot load.

HP recommends that you attempt to restore your system using the [Restoring and recovery methods on page 78](#).

### Creating a system restore

System Restore is available in Windows. The System Restore software can automatically or manually create restore points, or snapshots, of the system files and settings on the computer at a particular point.

When you use System Restore, it returns your computer to its state at the time you made the restore point. Your personal files and documents should not be affected.

### Restoring and recovery methods

After you run the first method, test to see whether the issue still exists before you proceed to the next method, which might now be unnecessary.

1. Run a Microsoft System Restore.
2. Run Reset this PC.



**NOTE:** The options **Remove everything** and then **Fully clean the drive** can take several hours to complete and leave no information on your computer. It is the safest way to reset your computer before you recycle it.

---

3. Recover using HP Recovery media. For more information, see [Recovering using HP Recovery media on page 78](#).

For more information about the first two methods, see the Get Help app:

Select the **Start** button, select the **Get Help** app, and then enter the task you want to perform.



**NOTE:** You must be connected to the internet to access the Get Help app.

---

### Recovering using HP Recovery media

You can use HP Recovery media to recover the original operating system and software programs that were installed at the factory. On select products, it can be created on a bootable USB flash drive using the HP Cloud Recovery Download Tool.

For details, see [Using the HP Cloud Recovery Download Tool to create recovery media \(select products only\) on page 77](#).



**NOTE:** If you cannot create recovery media yourself, contact support to obtain recovery discs. Go to <http://www.hp.com/support>, select your country or region, and then follow the on-screen instructions.

---

To recover your system:

- ▲ Insert the HP Recovery media, and then restart the computer.

---

 **NOTE:** HP recommends that you follow the [Restoring and recovery methods on page 78](#) to restore your computer before you obtain and use the HP recovery discs. Using a recent backup can return your machine to a working state sooner than using the HP recovery discs. After the system is restored, reinstalling all the operating system software released since your initial purchase can be a lengthy process.

---

## Changing the computer boot order

If your computer does not restart using the HP Recovery media, you can change the computer boot order, the order of devices listed in BIOS for startup information. You can select an optical drive or a USB flash drive, depending on the location of your HP Recovery media.

---

 **IMPORTANT:** For a tablet with a detachable keyboard, connect the tablet to the keyboard base before beginning these steps.

---

To change the boot order:

1. Insert the HP Recovery media.
2. Access the system **Startup** menu.
  - For computers or tablets with keyboards attached, turn on or restart the computer or tablet, quickly press **esc**, and then press **f9** for boot options.
  - For tablets without keyboards, turn on or restart the tablet, quickly press and hold the volume up button, and then select **f9**.

– or –

Turn on or restart the tablet, quickly press and hold the volume down button, and then select **f9**.
3. Select the optical drive or USB flash drive from which you want to boot, and then follow the on-screen instructions.

## Using HP Sure Recover (select products only)

Select computer models are configured with HP Sure Recover, a PC operating system (OS) recovery solution built into the hardware and software. HP Sure Recover can fully restore the HP OS image without installed recovery software.

Using HP Sure Recover, an administrator or user can restore the system and install:

- Latest version of the operating system
- Platform-specific device drivers
- Software applications, in the case of a custom image

To access the latest documentation for HP Sure Recover, go to <http://www.hp.com/support>. Follow the on-screen instructions to find your product and locate your documentation.



---

# 8 Using HP PC Hardware Diagnostics

You can use the HP PC Hardware Diagnostics utility to determine whether your computer hardware is running properly. The three versions are HP PC Hardware Diagnostics Windows, HP PC Hardware Diagnostics UEFI (Unified Extensible Firmware Interface), and (for select products only) Remote HP PC Hardware Diagnostics UEFI, a firmware feature.

## Using HP PC Hardware Diagnostics Windows (select products only)

HP PC Hardware Diagnostics Windows is a Windows-based utility that allows you to run diagnostic tests to determine whether the computer hardware is functioning properly. The tool runs within the Windows operating system to diagnose hardware failures.

If HP PC Hardware Diagnostics Windows is not installed on your computer, first you must download and install it. To download HP PC Hardware Diagnostics Windows, see [Downloading HP PC Hardware Diagnostics Windows on page 82](#).

## Using an HP PC Hardware Diagnostics Windows hardware failure ID code

When HP PC Hardware Diagnostics Windows detects a failure that requires hardware replacement, a 24-digit failure ID code is generated for select component tests. For interactive tests, such as keyboard, mouse, or audio and video palette, you must perform troubleshooting steps before you can receive a failure ID.

▲ You have several options after you receive a failure ID:

- Select **Next** to open the Event Automation Service (EAS) page, where you can log the case.  
– or –
- Scan the QR code with your mobile device, which takes you to the EAS page, where you can log the case.  
– or –
- Select the box next to the 24-digit failure ID to copy your failure code and send it to support.

## Accessing HP PC Hardware Diagnostics Windows

After HP PC Hardware Diagnostics Windows is installed, you can access it from HP Help and Support, HP Support Assistant, or the Start menu.

## Accessing HP PC Hardware Diagnostics Windows from HP Help and Support (select products only)

After HP PC Hardware Diagnostics Windows is installed, follow these steps to access it from HP Help and Support.

1. Select the **Start** button, and then select **HP Help and Support**.
2. Select **HP PC Hardware Diagnostics Windows**.
3. When the tool opens, select the type of diagnostic test that you want to run, and then follow the on-screen instructions.

---

 **NOTE:** To stop a diagnostic test, select **Cancel**.

---

## Accessing HP PC Hardware Diagnostics Windows from Support Assistant

After HP PC Hardware Diagnostics Windows is installed, follow these steps to access it from HP Support Assistant.

1. Type `support` in the taskbar search box, and then select the **HP Support Assistant** app.  
– or –  
Select the question mark icon in the taskbar.
2. Select **Troubleshooting and fixes**.
3. Select **Diagnostics**, and then select **HP PC Hardware Diagnostics Windows**.
4. When the tool opens, select the type of diagnostic test that you want to run, and then follow the on-screen instructions.

---

 **NOTE:** To stop a diagnostic test, select **Cancel**.

---

## Accessing HP PC Hardware Diagnostics Windows from the Start menu (select products only)

After HP PC Hardware Diagnostics Windows is installed, follow these steps to access it from the Start menu.

1. Select the **Start** button.
2. Right-click **HP PC Hardware Diagnostics for Windows**, select **More**, and then select **Run as administrator**.
3. When the tool opens, select the type of diagnostic test that you want to run, and then follow the on-screen instructions.

---

 **NOTE:** To stop a diagnostic test, select **Cancel**.

---

## Downloading HP PC Hardware Diagnostics Windows

The HP PC Hardware Diagnostics Windows downloading instructions are provided in English only. You must use a Windows computer to download this tool because only .exe files are provided.

### Downloading the latest HP PC Hardware Diagnostics Windows version from HP

To download HP PC Hardware Diagnostics Windows from HP, follow these steps.

1. Go to <http://www.hp.com/go/techcenter/pcdiags>. The HP PC Diagnostics home page is displayed.
2. Select **Download HP Diagnostics Windows**, and then select the specific Windows diagnostics version to download to your computer or a USB flash drive.

The tool downloads to the selected location.

## Downloading the HP PC Hardware Diagnostics Windows from the Microsoft Store

You can download the HP PC Hardware Diagnostics Windows from the Microsoft Store.

1. Select the Microsoft Store app on your desktop or enter `Microsoft Store` in the taskbar search box.
2. Enter `HP PC Hardware Diagnostics Windows` in the **Microsoft Store** search box.
3. Follow the on-screen directions.

The tool downloads to the selected location.

## Downloading HP Hardware Diagnostics Windows by product name or number (select products only)

You can download HP PC Hardware Diagnostics Windows by product name or number.

---

 **NOTE:** For some products, you might have to download the software to a USB flash drive by using the product name or number.

---

1. Go to <http://www.hp.com/support>.
2. Select **Software and Drivers**, select your type of product, and then enter the product name or number in the search box that is displayed.
3. In the **Diagnostics** section, select **Download**, and then follow the on-screen instructions to select the specific Windows diagnostics version to be downloaded to your computer or USB flash drive.

The tool downloads to the selected location.

## Installing HP PC Hardware Diagnostics Windows

To install HP PC Hardware Diagnostics Windows, navigate to the folder on your computer or the USB flash drive where the .exe file downloaded, double-click the .exe file, and then follow the on-screen instructions.

## Using HP PC Hardware Diagnostics UEFI

HP PC Hardware Diagnostics UEFI (Unified Extensible Firmware Interface) allows you to run diagnostic tests to determine whether the computer hardware is functioning properly. The tool runs outside the operating system so that it can isolate hardware failures from issues that are caused by the operating system or other software components.

---

 **NOTE:** For Windows 10 S computers, you must use a Windows computer and a USB flash drive to download and create the HP UEFI support environment because only .exe files are provided. For more information, see [Downloading HP PC Hardware Diagnostics UEFI to a USB flash drive on page 84](#).

---

If your PC does not start in Windows, you can use HP PC Hardware Diagnostics UEFI to diagnose hardware issues.

## Using an HP PC Hardware Diagnostics UEFI hardware failure ID code

When HP PC Hardware Diagnostics UEFI detects a failure that requires hardware replacement, a 24-digit failure ID code is generated.

For assistance in solving the problem:

- ▲ Select **Contact HP**, accept the HP privacy disclaimer, and then use a mobile device to scan the failure ID code that appears on the next screen. The HP Customer Support – Service Center page appears with your failure ID and product number automatically filled in. Follow the on-screen instructions.

– or –

Contact support, and provide the failure ID code.

---

 **NOTE:** To start diagnostics on a convertible computer, your computer must be in notebook mode, and you must use the attached keyboard.

 **NOTE:** If you need to stop a diagnostic test, press `esc`.

---

## Starting HP PC Hardware Diagnostics UEFI

To start HP PC Hardware Diagnostics UEFI, follow this procedure.

1. Turn on or restart the computer, and quickly press `esc`.
2. Press `f2`.

The BIOS searches three places for the diagnostic tools, in the following order:

- a. Connected USB flash drive

---

 **NOTE:** To download the HP PC Hardware Diagnostics UEFI tool to a USB flash drive, see [Downloading the latest HP PC Hardware Diagnostics UEFI version on page 84](#).

---

- b. Hard drive

- c. BIOS

3. When the diagnostic tool opens, select a language, select the type of diagnostic test you want to run, and then follow the on-screen instructions.

## Downloading HP PC Hardware Diagnostics UEFI to a USB flash drive

Downloading HP PC Hardware Diagnostics UEFI to a USB flash drive can be useful in some situations.

- HP PC Hardware Diagnostics UEFI is not included in the preinstallation image.
- HP PC Hardware Diagnostics UEFI is not included in the HP Tool partition.
- The hard drive is damaged.

---

 **NOTE:** The HP PC Hardware Diagnostics UEFI downloading instructions are provided in English only, and you must use a Windows computer to download and create the HP UEFI support environment because only .exe files are provided.

---

## Downloading the latest HP PC Hardware Diagnostics UEFI version

To download the latest HP PC Hardware Diagnostics UEFI version to a USB flash drive, follow this procedure.

1. Go to <http://www.hp.com/go/techcenter/pcdiags>. The HP PC Diagnostics home page is displayed.
2. Select **Download HP Diagnostics UEFI**, and then select **Run**.

## Downloading HP PC Hardware Diagnostics UEFI by product name or number (select products only)

You can download HP PC Hardware Diagnostics UEFI by product name or number (select products only) to a USB flash drive.

---

 **NOTE:** For some products, you might have to download the software to a USB flash drive by using the product name or number.

---

1. Go to <http://www.hp.com/support>.
2. Enter the product name or number, select your computer, and then select your operating system.
3. In the **Diagnostics** section, follow the on-screen instructions to select and download the specific UEFI Diagnostics version for your computer.

## Using Remote HP PC Hardware Diagnostics UEFI settings (select products only)

Remote HP PC Hardware Diagnostics UEFI is a firmware (BIOS) feature that downloads HP PC Hardware Diagnostics UEFI to your computer. It can then execute the diagnostics on your computer, and it might upload results to a preconfigured server.

For more information about Remote HP PC Hardware Diagnostics UEFI, go to <http://www.hp.com/go/techcenter/pcdiags>, and then select **Find out more**.

## Downloading Remote HP PC Hardware Diagnostics UEFI

HP Remote PC Hardware Diagnostics UEFI is also available as a SoftPak that you can download to a server.

## Downloading the latest Remote HP PC Hardware Diagnostics UEFI version

You can download the latest HP PC Hardware Diagnostics UEFI version to a USB flash drive.

1. Go to <http://www.hp.com/go/techcenter/pcdiags>. The HP PC Diagnostics home page is displayed.
2. Select **Download Remote Diagnostics**, and then select **Run**.

## Downloading Remote HP PC Hardware Diagnostics UEFI by product name or number

You can download HP Remote PC Hardware Diagnostics UEFI by product name or number.

---

 **NOTE:** For some products, you might have to download the software by using the product name or number.

---

1. Go to <http://www.hp.com/support>.
2. Select **Software and Drivers**, select your type of product, enter the product name or number in the search box that is displayed, select your computer, and then select your operating system.
3. In the **Diagnostics** section, follow the on-screen instructions to select and download the **Remote UEFI** version for the product.

## Customizing Remote HP PC Hardware Diagnostics UEFI settings

Using the Remote HP PC Hardware Diagnostics setting in Computer Setup (BIOS), you can perform several customizations.

- Set a schedule for running diagnostics unattended. You can also start diagnostics immediately in interactive mode by selecting **Execute Remote HP PC Hardware Diagnostics**.
- Set the location for downloading the diagnostic tools. This feature provides access to the tools from the HP website or from a server that has been preconfigured for use. Your computer does not require the traditional local storage (such as a hard drive or USB flash drive) to run remote diagnostics.
- Set a location for storing the test results. You can also set the user name and password that you use for uploads.
- Display status information about the diagnostics run previously.

To customize Remote HP PC Hardware Diagnostics UEFI settings, follow these steps:

1. Turn on or restart the computer, and when the HP logo appears, press **f10** to enter Computer Setup.
2. Select **Advanced**, and then select **Settings**.
3. Make your customization selections.
4. Select **Main**, and then **Save Changes and Exit** to save your settings.

Your changes take effect when the computer restarts.

---

# 9 Computer Setup (BIOS), TPM, and HP Sure Start

HP provides several tools to help set up and protect your computer.

## Using Computer Setup

Computer Setup, or Basic Input/Output System (BIOS), controls communication between all the input and output devices on the system (such as hard drives, display, keyboard, mouse, and printer). Computer Setup includes settings for types of devices installed, the startup sequence of the computer, and amount of system and extended memory.

---

 **NOTE:** Use extreme care when making changes in Computer Setup. Errors can prevent the computer from operating properly.

---

To start Computer Setup, turn on or restart the computer, and when the HP logo appears, press **f10** to enter Computer Setup.

## Navigating and selecting in Computer Setup

You can navigate and select in Computer Setup using one or more methods.

- To select a menu or a menu item, use the **tab** key and the keyboard arrow keys and then press **enter**, or use a pointing device to select the item.
- To scroll up and down, select the up arrow or the down arrow in the upper-right corner of the screen, or use the up arrow key or the down arrow key on the keyboard.
- To close open dialog boxes and return to the main Computer Setup screen, press **esc**, and then follow the on-screen instructions.

To exit Computer Setup, choose one of the following methods:

- To exit Computer Setup menus without saving your changes, select **Main**, select **Ignore Changes and Exit**, and then select **Yes**.

---

 **NOTE:** If you are using arrow keys to highlight your choice, you must then press **enter**.

---

- To save your changes and exit Computer Setup menus, select **Main**, select **Save Changes and Exit**, and then select **Yes**.

---

 **NOTE:** If you are using arrow keys to highlight your choice, you must then press **enter**.

---

Your changes go into effect when the computer restarts.

## Restoring factory settings in Computer Setup

To return all settings in Computer Setup to the values that were set at the factory, follow these steps.

---

 **NOTE:** Restoring defaults will not change the hard drive mode.

---

1. Start Computer Setup. See [Using Computer Setup on page 87](#).
2. Select **Main**, select **Apply Factory Defaults and Exit**, and then select **Yes**.

---

 **NOTE:** If you are using arrow keys to highlight your choice, you must then press [enter](#).

 **NOTE:** On select products, the selections might display **Restore Defaults** instead of **Apply Factory Defaults and Exit**.

---

Your changes go into effect when the computer restarts.

---

 **NOTE:** Your password settings and security settings are not changed when you restore the factory settings.

---

## Updating the BIOS

Updated versions of the BIOS might be available on the HP website. Most BIOS updates on the HP website are packaged in compressed files called *SoftPaqs*.

Some download packages contain a file named *Readme.txt*, which contains information regarding installing and troubleshooting the file.

### Determining the BIOS version

To decide whether you need to update Computer Setup (BIOS), first determine the BIOS version on your computer.

You can access BIOS version information (also known as *ROM date* and *System BIOS*) by pressing **fn+esc** (if you are already in Windows) or by using Computer Setup.

1. Start Computer Setup. See [Using Computer Setup on page 87](#).
2. Select **Main**, and then select **System Information**.
3. To exit Computer Setup menus without saving your changes, select **Main**, select **Ignore Changes and Exit**, and then select **Yes**.

---

 **NOTE:** If you are using arrow keys to highlight your choice, you must then press [enter](#).

---

To check for later BIOS versions, see [Preparing for a BIOS update on page 88](#).

### Preparing for a BIOS update

Be sure to follow all prerequisites before downloading and installing a BIOS update.

---

 **IMPORTANT:** To reduce the risk of damage to the computer or an unsuccessful installation, download and install a BIOS update only when the computer is connected to reliable external power using the AC adapter. Do not download or install a BIOS update while the computer is running on battery power, docked in an optional docking device, or connected to an optional power source. During the download and installation, follow these instructions:

Do not disconnect power on the computer by unplugging the power cord from the AC outlet.

Do not shut down the computer or initiate Sleep.

Do not insert, remove, connect, or disconnect any device, cable, or cord.

---

## Downloading a BIOS update

After you review the prerequisites, you can check for and download BIOS updates.

1. Type `support` in the taskbar search box, and then select the HP Support Assistant app.  
– or –  
Select the question mark icon in the taskbar.
2. Select **Updates**, and then select **Check for updates and messages**.
3. Follow the on-screen instructions.
4. At the download area, follow these steps:
  - a. Identify the most recent BIOS update and compare it to the BIOS version currently installed on your computer. Make a note of the date, name, or other identifier. You might need this information to locate the update later, after it has been downloaded to your hard drive.
  - b. Follow the on-screen instructions to download your selection to the hard drive.  
  
Make a note of the path to the location on your hard drive where the BIOS update is downloaded. You will need to access this path when you are ready to install the update.

---

 **NOTE:** If you connect your computer to a network, consult the network administrator before installing any software updates, especially system BIOS updates.

---

## Installing a BIOS update

BIOS installation procedures vary. Follow any instructions that are displayed on the screen after the download is complete. If no instructions are displayed, follow these steps.

1. Type `file` in the taskbar search box, and then select **File Explorer**.
2. Select your hard drive designation. The hard drive designation is typically Local Disk (C:).
3. Using the hard drive path you recorded earlier, open the folder that contains the update.
4. Double-click the file that has an `.exe` extension (for example, *filename.exe*).  
  
The BIOS installation begins.
5. Complete the installation by following the on-screen instructions.

---

 **NOTE:** After a message on the screen reports a successful installation, you can delete the downloaded file from your hard drive.

---

## Changing the boot order using the f9 prompt

To dynamically choose a boot device for the current startup sequence, follow these steps.

1. Access the Boot Device Options menu:
  - Turn on or restart the computer, and when the HP logo appears, press **F9** to enter the Boot Device Options menu.
2. Select a boot device, press **enter**, and then follow the on-screen instructions.

## TPM BIOS settings (select products only)

TPM provides additional security for your computer. You can modify the TPM settings in Computer Setup (BIOS).

---

 **IMPORTANT:** Before enabling Trusted Platform Module (TPM) functionality on this system, you must ensure that your intended use of TPM complies with relevant local laws, regulations and policies, and approvals or licenses must be obtained if applicable. For any compliance issues arising from your operation or usage of TPM that violates the previously mentioned requirement, you shall bear all the liabilities wholly and solely. HP will not be responsible for any related liabilities.

 **NOTE:** If you change the TPM setting to Hidden, TPM is not visible in the operating system.

---

To access TPM settings in Computer Setup:

1. Start Computer Setup. See [Using Computer Setup on page 87](#).
2. Select **Security**, select **TPM Embedded Security**, and then follow the on-screen instructions.

## Using HP Sure Start (select products only)

Select computer models are configured with HP Sure Start, a technology that monitors the computer's BIOS for attacks or corruption. If the BIOS becomes corrupted or is attacked, HP Sure Start automatically restores the BIOS to its previously safe state, without user intervention.

HP Sure Start is configured and already enabled so that most users can use the HP Sure Start default configuration. Advanced users can customize the default configuration.

To access the latest documentation on HP Sure Start, go to <http://www.hp.com/support>. Select **Find your product**, and then follow the on-screen instructions.

# 10 Specifications

This chapter provides specifications for your computer.

## Computer specifications

This section provides specifications for your computer. When traveling with your computer, the computer dimensions and weights, as well as input power ratings and operating specifications, provide helpful information.

**Table 10-1 Computer specifications**

	Metric	U.S.
<b>Dimensions</b>		
Width	307.6 mm	12.11 in
Depth	204.5 mm	8.05 in
Height (400 nit panel and above)	17.95 mm	0.71 in
Height (250 nit panel)	19.2 mm	0.76 in
<b>Weight</b>		
400 nit panel, no WWAN, 42 Whr battery	0.999 kg	2.20 lbs
400 nit panel, WWAN, 53 Whr battery	1.079 kg	2.38 lbs
250 nit panel, no WWAN, 53 Whr battery	1.149 kg	2.53 lbs
<b>Input power</b>		
Operating voltage and current	19.5 V dc @ 2.31 A – 45 W	
	19.5 V dc @ 3.33 A – 65 W	
<b>Temperature</b>		
Operating	5°C to 35°C	41°F to 95°F
Nonoperating	–20°C to 60°C	–4°F to 140°F
<b>Relative humidity (noncondensing)</b>		
Operating	10% to 90%	
Nonoperating	5% to 95%	
<b>Maximum altitude (unpressurized)</b>		
Operating	–15 m to 3,048 m	–50 ft to 10,000 ft
Nonoperating	–15 m to 12,192 m	–50 ft to 40,000 ft

**Table 10-1 Computer specifications (continued)**

	Metric	U.S.
<b>NOTE:</b> Applicable product safety standards specify thermal limits for plastic surfaces. The device operates well within this range of temperatures.		

## 33.8 cm (13.3 in) display specifications

This section provides specifications for your display.

**Table 10-2 Display specifications**

	Metric	U.S.
Active diagonal size	<b>33.8 cm</b>	13.3 in
Resolution	1920 × 1080	
Surface treatment	Antiglare	
Brightness	250 nits (45% CG panels) 400 nits (sRGB 100% panels) 1000 nits (72% CG panels)	
Viewing angle	UWVA	
Backlight	LED	
Display panel interface	eDP	

## Solid-state drive specifications

This section provides specifications for your solid-state drives.

**Table 10-3 Solid-state drive specifications**

	256 GB*	512 GB*	1 TB*
<b>Dimensions</b>			
Height	1.0 mm	1.0 mm	1.0 mm
Length	50.8 mm	50.8 mm	50.8 mm
Width	28.9 mm	28.9 mm	28.9 mm
Weight	< 10 g	< 10 g	< 10 g
<b>Interface type</b>			
Ready time, maximum (to not busy)	1.0 ms	< 1.0 ms	1.0 ms
Access times, logical	0.1 ms	0.1 ms	0.1 ms
<b>Transfer rate</b>			
Sequential read	up to 2150 MB/s	up to 2150 MB/s	up to 2150 MB/s
Random read	Up to 300,000 IOPs	Up to 300,000 IOPs	Up to 300,000 IOPs
Sequential write	up to 1550 MB/s	up to 1550 MB/s	up to 1550 MB/s

**Table 10-3 Solid-state drive specifications (continued)**

	256 GB*	512 GB*	1 TB*
Random write	Up to 100,000 IOPs	Up to 100,000 IOPs	Up to 100,000 IOPs
<b>Total logical sectors</b>	468,883,296	1,000,215,216	1,500,336,388
<b>Operating temperature</b>	<b>0°C to 70°C (32°F to 158°F)</b>		
*1 GB = 1 billion bytes when referring to hard drive storage capacity. Actual accessible capacity is less. Actual drive specifications can differ slightly.			
<b>NOTE:</b> Certain restrictions and exclusions apply. Contact support for details.			

## Solid-state drive specifications (SATA-3)

This section provides specifications for your solid-state drive.

**Table 10-4 Solid-state drive specifications**

	128 GB*
<b>Dimensions</b>	
Height	1.35 mm
Weight	< 10 g
<b>Interface type</b>	SATA-3
Ready time, maximum (to not busy)	1.0 ms
Access times, logical	0.1 ms
<b>Transfer rate</b>	up to 540 MB/s
<b>Total logical sectors</b>	234,441,648
<b>Operating temperature</b>	<b>0°C to 70°C (32°F to 158°F)</b>
*1 GB = 1 billion bytes when referring to hard drive storage capacity. Actual accessible capacity is less. Actual drive specifications can differ slightly.	
<b>NOTE:</b> Certain restrictions and exclusions apply. Contact support for details.	



---

# 11 Statement of memory volatility

For general information regarding nonvolatile memory in HP business computers, and to restore nonvolatile memory that can contain personal data after the system has been turned off and the hard drive has been removed, use these instructions.

HP business computer products that use Intel®-based or AMD®-based system boards contain volatile DDR memory. The amount of nonvolatile memory present in the system depends upon the system configuration. Intel-based and AMD-based system boards contain nonvolatile memory subcomponents as originally shipped from HP, with the following assumptions:

- No subsequent modifications were made to the system.
- No applications, features, or functionality were added to or installed on the system.

Following system shutdown and removal of all power sources from an HP business computer system, personal data can remain on volatile system memory (DIMMs) for a finite period of time and also remains in nonvolatile memory. Use the following steps to remove personal data from the computer, including the nonvolatile memory found in Intel-based and AMD-based system boards.

---

 **NOTE:** If your tablet has a keyboard base, connect to the keyboard base before beginning steps in this chapter.

---

## Current BIOS steps

Use these instructions to restore nonvolatile memory.

1. Follow these steps to restore the nonvolatile memory that can contain personal data. Restoring or reprogramming nonvolatile memory that does not store personal data is neither necessary nor recommended.

- a. Turn on or restart the computer, and then quickly press **esc**.

---

 **NOTE:** If the system has a BIOS administrator password, enter the password at the prompt.

---

- b. Select **Main**, select **Apply Factory Defaults and Exit**, and then select **Yes** to load defaults. The computer restarts.
- c. During the restart, press **esc** while the "Press the ESC key for Startup Menu" message is displayed at the bottom of the screen.

---

 **NOTE:** If the system has a BIOS administrator password, enter the password at the prompt.

---

- d. Select the **Security** menu, select **Restore Security Settings to Factory Defaults**, and then select **Yes** to restore security level defaults. The computer reboots.

- e. During the reboot, press `esc` while the "Press the ESC key for Startup Menu" message is displayed at the bottom of the screen.



---

**NOTE:** If the system has a BIOS administrator password, enter the password at the prompt.

---

- f. If an asset or ownership tag is set, select the **Security** menu and scroll down to the **Utilities** menu. Select **System IDs**, and then select **Asset Tracking Number**. Clear the tag, and then make the selection to return to the prior menu.
- g. If a DriveLock password is set, select the **Security** menu, and scroll down to **Hard Drive Utilities** under the **Utilities** menu. Select **Hard Drive Utilities**, select **DriveLock**, and then clear the check box for **DriveLock password on restart**. Select **OK** to proceed.
- h. Select the **Main** menu, and then select **Reset BIOS Security to factory default**. Select **Yes** at the warning message. The computer reboots.
- i. During the reboot, press `esc` while the "Press the ESC key for Startup Menu" message is displayed at the bottom of the screen.



---

**NOTE:** If the system has a BIOS administrator password, enter the password at the prompt.

---

- j. Select the **Main** menu, select **Apply Factory Defaults and Exit**, select **Yes** to save changes and exit, and then select **Shutdown**.
  - k. Reboot the system. If the system has a Trusted Platform Module (TPM), fingerprint reader, or both, one or two prompts will appear—one to clear the TPM and the other to Reset Fingerprint Sensor. Press or tap `f1` to accept or `f2` to reject.
  - l. Remove all power and system batteries for at least 24 hours.
2. Complete one of the following:
- Remove and retain the storage drive.  
– or –
  - Clear the drive contents by using a third-party utility designed to erase data from an SSD.  
– or –
  - Clear the contents of the drive by using the following BIOS Setup Secure Erase command option steps:



---

**NOTE:** If you clear data using Secure Erase, you cannot recover it.

---

- a. Turn on or restart the computer, and then quickly press `esc`.
- b. Select the **Security** menu and scroll down to the `esc` menu.
- c. Select **Hard Drive Utilities**.
- d. Under **Utilities**, select **Secure Erase**, select the hard drive storing the data you want to clear, and then follow the on-screen instructions to continue.

– or –

Clear the contents of the drive using the following Disk Sanitizer commands steps:

- i. Turn on or restart the computer, and then quickly press `esc`.

- ii. Select the **Security** menu and scroll down to the **Utilities** menu.
- iii. Select **Hard Drive Utilities**.
- iv. Under **Utilities**, select **Disk Sanitizer**, select the hard drive with the data that you want to clear, and then follow the on-screen instructions to continue.

 **NOTE:** The amount of time it takes for Disk Sanitizer to run can take several hours. Plug the computer into an AC outlet before starting.

## Nonvolatile memory usage

Use this table to troubleshooting nonvolatile memory usage.

**Table 11-1** Troubleshooting steps for nonvolatile memory usage

Nonvolatile memory type	Amount (Size)	Does this memory store customer data?	Does this memory retain data when power is removed?	What is the purpose of this memory?	How is data entered into this memory?	How is this memory write-protected?
HP Sure Start flash (select models only)	8 MB	No	Yes	Provides protected backup of critical System BIOS code, EC firmware, and critical computer configuration data for select platforms that support HP Sure Start.  For more information, see <a href="#">Using HP Sure Start (select products only) on page 101</a> .	Data cannot be written to this device via the host processor. The content is managed solely by the HP Sure Start Embedded Controller.	This memory is protected by the HP Sure Start Embedded Controller.
Real Time Clock (RTC) battery backed-up CMOS configuration memory	256 bytes	No	Yes	Stores system date and time and noncritical data.	RTC battery backed-up CMOS is programmed using Computer Setup (BIOS), or by changing the Windows date & time.	This memory is not write-protected.
Controller (NIC) EEPROM	64 KB (not customer accessible)	No	Yes	Stores NIC configuration and NIC firmware.	NIC EEPROM is programmed using a utility from the NIC vendor that can be run from DOS.	A utility must be used to write data to this memory and is available from the NIC vendor. Writing data to this ROM in an inappropriate manner will render the NIC non-functional.
DIMM Serial Presence Detect (SPD) configuration data	256 bytes per memory module, 128 bytes programmable	No	Yes	Stores memory module information.	DIMM SPD is programmed by the memory vendor.	Data cannot be written to this memory when the module is installed in a computer. The specific

Table 11-1 Troubleshooting steps for nonvolatile memory usage (continued)

Nonvolatile memory type	Amount (Size)	Does this memory store customer data?	Does this memory retain data when power is removed?	What is the purpose of this memory?	How is data entered into this memory?	How is this memory write-protected?
						write-protection method varies by memory vendor.
System BIOS	9 MB	Yes	Yes	Stores system BIOS code and computer configuration data.	System BIOS code is programmed at the factory. Code is updated when the system BIOS is updated. Configuration data and settings are entered using the Computer Setup (BIOS) or a custom utility.	<p><b>NOTE:</b> Writing data to this ROM in an inappropriate manner can render the computer non-functional.</p> <p>A utility must be used for writing data to this memory and is available on the HP website; go to <a href="http://www.hp.com/support">http://www.hp.com/support</a>. Select <b>Find your product</b>, and then follow the on-screen instructions.</p>
Intel Management Engine Firmware (present only in select Elite or Z models. For more information, go to <a href="http://www.hp.com/support">http://www.hp.com/support</a> . Select <b>Identify your product for manuals and specific product information</b> , and then follow the on-screen instructions.)	1.5 MB or 7 MB	Yes	Yes	Stores Management Engine Code, Settings, Provisioning Data and iAMT third-party data store.	Management Engine Code is programmed at the factory. Code is updated via Intel secure firmware update utility. Unique Provisioning Data can be entered at the factory or by an administrator using the Management Engine (MEBx) setup utility. The third-party data store contents can be populated by a remote management console or local applications that have been registered by an administrator to have access to the space.	The Intel chipset is configured to enforce hardware protection to block all direct read-write access to this area. An Intel utility must be used for updating the firmware. Only firmware updates digitally signed by Intel can be applied using this utility.
Bluetooth flash (select products only)	2 megabits	No	Yes	Stores Bluetooth configuration and firmware.	Bluetooth flash is programmed at the factory. Tools for writing data to this memory are not publicly available but can be obtained from the silicon vendor.	A utility must be used for writing data to this memory and is made available through newer versions of the driver whenever the flash requires an upgrade.
802.11 WLAN EEPROM	4 kilobits to 8 kilobits	No	Yes	Stores configuration and calibration data.	802.11 WLAN EEPROM is programmed at the factory. Tools for writing data to this memory are not made public.	A utility must be used for writing data to this memory and is typically not made available to the public unless a firmware upgrade is necessary to address a unique issue.

**Table 11-1** Troubleshooting steps for nonvolatile memory usage (continued)

Nonvolatile memory type	Amount (Size)	Does this memory store customer data?	Does this memory retain data when power is removed?	What is the purpose of this memory?	How is data entered into this memory?	How is this memory write-protected?
Camera (select products only)	64 kilobits	No	Yes	Stores camera configuration and firmware.	Camera memory is programmed using a utility from the device manufacturer that can be run from Windows.	A utility must be used for writing data to this memory and is typically not made available to the public unless a firmware upgrade is necessary to address a unique issue.
Fingerprint reader (select products only)	512 KB flash	Yes	Yes	Stores fingerprint templates.	Fingerprint reader memory is programmed by user enrollment in HP ProtectTools Security Manager.	Only a digitally signed application can make the call to write to the flash.

## Questions and answers

Use this section to answer your questions about nonvolatile memory.

### 1. How can the BIOS settings be restored (returned to factory settings)?

 **IMPORTANT:** The restore defaults feature does not securely erase any information on your hard drive. See question and answer 6 for steps to securely erase information.

The restore defaults feature does not reset the Custom Secure Boot keys. See question and answer 7 for information about resetting the keys.

- Turn on or restart the computer, and then quickly press *esc*.
- Select **Main**, and then select **Apply Factory Defaults and Exit**.
- Follow the on-screen instructions.
- Select **Main**, select **Save Changes and Exit**, and then follow the on-screen instructions.

### 2. What is a UEFI BIOS, and how is it different from a legacy BIOS?

The Unified Extensible Firmware Interface (UEFI) BIOS is an industry-standard software interface between the platform firmware and an operating system (OS). It replaces the older BIOS architecture but supports much of the legacy BIOS functionality.

Like the legacy BIOS, the UEFI BIOS provides an interface to display the system information and configuration settings and to change the configuration of your computer before an OS is loaded. BIOS provides a secure runtime environment that supports a Graphic User Interface (GUI). In this environment, you can use either a pointing device (touch screen, touchpad, pointing stick, or USB mouse) or the keyboard to navigate and make menu and configuration selections. The UEFI BIOS also contains basic system diagnostics.

The UEFI BIOS provides functionality beyond that of the legacy BIOS. In addition, the UEFI BIOS works to initialize the computer's hardware before loading and executing the OS; the runtime environment allows the loading and execution of software programs from storage devices to provide more functionality, such as advanced hardware diagnostics (with the ability to display more detailed system information) and advanced firmware management and recovery software.

HP has provided options in Computer Setup (BIOS) to allow you to run in legacy BIOS, if required by the operating system. Examples of this requirement would be if you upgrade or downgrade the OS.

### 3. Where is the UEFI BIOS located?

The UEFI BIOS is located on a flash memory chip. You must use a utility to write to the chip.

### 4. What kind of configuration data is stored on the DIMM Serial Presence Detect (SPD) memory module? How would this data be written?

The DIMM SPD memory contains information about the memory module, such as size, serial number, data width, speed and timing, voltage, and thermal information. This information is written by the module manufacturer and stored on an EEPROM. You cannot write to this EEPROM when the memory module is installed in a computer. Third-party tools do exist that can write to the EEPROM when the memory module is not installed in a computer. Various third-party tools are available to read SPD memory.

### 5. What is meant by "Restore the nonvolatile memory found in Intel-based system boards"?

This message relates to clearing the Real Time Clock (RTC) CMOS memory that contains computer configuration data.

### 6. How can the BIOS security be reset to factory defaults and erase the data?

---

 **IMPORTANT:** Resetting results in the loss of information.

These steps do not reset Custom Secure Boot Keys. See question and answer 7 for information about resetting the keys.

---

- a. Turn on or restart the computer, and then quickly press **esc**.
- b. Select **Main**, and then select **Reset Security to Factory Defaults**.
- c. Follow the on-screen instructions.
- d. Select **Main**, select **Save Changes and Exit**, and then follow the on-screen instructions.

### 7. How can the Custom Secure Boot Keys be reset?

Secure Boot is a feature to ensure that only authenticated code can start on a platform. If you enabled Secure Boot and created Custom Secure Boot Keys, disabling Secure Boot does not clear the keys. You must also select to clear the Custom Secure Boot Keys. Use the same Secure Boot access procedure that you used to create the Custom Secure Boot Keys, but select to clear or delete all Secure Boot Keys.

- a. Turn on or restart the computer, and then quickly press **esc**.
- b. Select the **Security** menu, select **Secure Boot Configuration**, and then follow the on-screen instructions.
- c. At the **Secure Boot Configuration** window, select **Secure Boot**, select **Clear Secure Boot Keys**, and then follow the on-screen instructions to continue.

## Using HP Sure Start (select products only)

Select computer models are configured with HP Sure Start, a technology that continuously monitors your computer's BIOS for attacks or corruption.

If the BIOS becomes corrupted or is attacked, HP Sure Start restores the BIOS to its previously safe state, without user intervention. Those select computer models ship with HP Sure Start configured and enabled. HP Sure Start is configured and already enabled so that most users can use the HP Sure Start default configuration. Advanced users can customize the default configuration.

To access the latest documentation on HP Sure Start, go to <http://www.hp.com/support>.



# 12 Power cord set requirements

This chapter provides power cord requirements for countries and regions.

The wide-range input feature of the computer permits it to operate from any line voltage from 100 V ac to 120 V ac, or from 220 V ac to 240 V ac.

The three-conductor power cord set included with the computer meets the requirements for use in the country or region where the equipment is purchased.

Power cord sets for use in other countries or regions must meet the requirements of the country and region where the computer is used.

## Requirements for all countries

These power cord requirements are applicable to all countries and regions.

- The length of the power cord set must be at least **1.0 m** (3.3 ft) and no more than **2.0 m** (6.5 ft).
- All power cord sets must be approved by an acceptable accredited agency responsible for evaluation in the country or region where the power cord set will be used.
- The power cord sets must have a minimum current capacity of 10 A and a nominal voltage rating of 125 V ac or 250 V ac, as required by the power system of each country or region.
- The appliance coupler must meet the mechanical configuration of an EN 60 320/IEC 320 Standard Sheet C13 connector for mating with the appliance inlet on the back of the computer.

## Requirements for specific countries and regions

To determine power cord requirements for specific countries and regions, use this table.

**Table 12-1** Power cord requirements for specific countries and regions

Country/region	Accredited agency	Applicable note number
Argentina	IRAM	1
Australia	SAA	1
Austria	OVE	1
Belgium	CEBEC	1
Brazil	ABNT	1
Canada	CSA	2

**Table 12-1 Power cord requirements for specific countries and regions (continued)**

Country/region	Accredited agency	Applicable note number
Chile	IMQ	1
Denmark	DEMKO	1
Finland	FIMKO	1
France	UTE	1
Germany	VDE	1
India	BIS	1
Israel	SII	1
Italy	IMQ	1
Japan	JIS	3
Netherlands	KEMA	1
New Zealand	SANZ	1
Norway	NEMKO	1
People's Republic of China	CCC	4
Saudi Arabia	SASO	7
Singapore	PSB	1
South Africa	SABS	1
South Korea	KTL	5
Sweden	SEMKO	1
Switzerland	SEV	1
Taiwan	BSMI	6
Thailand	TISI	1
United Kingdom	ASTA	1
United States	UL	2

1. The flexible cord must be Type H05VV-F, three-conductor, 0.75 mm<sup>2</sup> conductor size. Power cord set fittings (appliance coupler and wall plug) must bear the certification mark of the agency responsible for evaluation in the country or region where it will be used.
2. The flexible cord must be Type SVT/SJT or equivalent, No. 18 AWG, three-conductor. The wall plug must be a two-pole grounding type with a NEMA 5-15P (15 A, 125 V ac) or NEMA 6-15P (15 A, 250 V ac) configuration. CSA or C-UL mark. UL file number must be on each element.
3. The appliance coupler, flexible cord, and wall plug must bear a T mark and registration number in accordance with the Japanese Dentori Law. The flexible cord must be Type VCTF, three-conductor, 0.75 mm<sup>2</sup> or 1.25 mm<sup>2</sup> conductor size. The wall plug must be a two-pole grounding type with a Japanese Industrial Standard C8303 (7 A, 125 V ac) configuration.
4. The flexible cord must be Type RVV, three-conductor, 0.75 mm<sup>2</sup> conductor size. Power cord set fittings (appliance coupler and wall plug) must bear the CCC certification mark.
5. The flexible cord must be Type H05VV-F three-conductor, 0.75 mm<sup>2</sup> conductor size. KTL logo and individual approval number must be on each element. Approval number and logo must be printed on a flag label.
6. The flexible cord must be Type HVCTF three-conductor, 1.25 mm<sup>2</sup> conductor size. Power cord set fittings (appliance coupler, cable, and wall plug) must bear the BSMI certification mark.

**Table 12-1 Power cord requirements for specific countries and regions (continued)**

Country/region	Accredited agency	Applicable note number
7.	For 127 V ac, the flexible cord must be Type SVT or SJT 3-conductor, 18 AWG, with plug NEMA 5-15P (15 A, 125 V ac), with UL and CSA or C-UL marks. For 240 V ac, the flexible cord must be Type H05VV-F three-conductor, 0.75 mm <sup>2</sup> or 1.00 mm <sup>2</sup> conductor size, with plug BS 1363/A with BSI or ASTA marks.	



---

## 13 Recycling

When a nonrechargeable or rechargeable battery has reached the end of its useful life, do not dispose of the battery in general household waste. Follow the local laws and regulations in your area for battery disposal.

HP encourages customers to recycle used electronic hardware, HP original print cartridges, and rechargeable batteries. For more information about recycling programs, see the HP website at <http://www.hp.com/recycle>.



# Index

## A

- AC adapters, spare part numbers.... 26
- audio-out (headphone)/audio-in (microphone) combo jack, identifying.....6
- audio, product description.....2

## B

- backup, creating..... 77
- backups..... 77
- battery
  - illustrated..... 23
  - removal..... 43
  - spare part numbers..... 23, 43
- battery light..... 6
- BIOS
  - determining version..... 88
  - downloading an update..... 88, 89
  - updating..... 88
- Bluetooth label..... 13
- boot order
  - changing using the f9 prompt ... 89
- boot order, changing..... 79
- bottom..... 13
- bottom cover
  - illustrated..... 22
  - removal..... 35
  - spare part number..... 22, 35
- buttons
  - left touchpad..... 9
  - power..... 11, 12
  - right touchpad..... 9

## C

- Cable Kit
  - spare part number.....25
- camera..... 7
  - identifying.....7
- camera light, identifying..... 7
- camera privacy cover, identifying..... 7
- caps lock light, identifying..... 10

## cautions

- electrostatic discharge..... 29, 30
- chipset, product description..... 1
- components
  - bottom..... 13
  - display..... 7
  - keyboard area..... 8
  - left side..... 6
  - right side..... 5
- computer major components..... 17
- Computer Setup
  - navigating and selecting.....87
  - restoring factory settings..... 88
  - starting..... 87
- computer specifications..... 91
- connector, power..... 5, 6

## D

- display
  - specifications..... 91, 92
- display assembly
  - subcomponents..... 23
- display back cover
  - illustrated..... 23
  - spare part number.....23
- display bezel
  - illustrated..... 23
  - spare part number.....23
- display cable
  - illustrated..... 23
  - spare part number.....23
- display components..... 7
- display panel
  - illustrated..... 23
  - product description..... 1
  - spare part number.....23

## E

- electrostatic discharge (ESD).... 29, 30
  - preventing damage..... 29-31
- esc key, identifying..... 12

## F

- fan
  - illustrated..... 22
  - removal..... 54
  - spare part number..... 22, 54
- fingerprint reader
  - illustrated..... 23
  - spare part number.....23
- fingerprint reader board
  - removal..... 52
  - spare part number.....52
- fingerprint reader insert
  - spare part number.....26
- fingerprint reader, identifying..... 12
- fn key, identifying..... 12
- fn lock light, identifying..... 10

## G

- grounding methods..... 29-31
- guidelines
  - packaging..... 29, 33
  - transporting..... 29, 33
  - workstation..... 29

## H

- hard drive
  - product description..... 1
  - specifications..... 91
- HDMI port, identifying.....5
- heat sink
  - illustrated..... 22
  - removal..... 55
  - spare part number..... 22, 55
- hinge
  - illustrated..... 23
  - spare part number.....23
- hinge cover
  - illustrated..... 23
  - spare part number.....23
- HP PC Hardware Diagnostics UEFI
  - downloading..... 84
  - failure ID code.....83

starting.....	84
using.....	83
HP PC Hardware Diagnostics Windows	
accessing.....	81, 82
downloading.....	82, 83
failure ID code.....	81
installing.....	83
using.....	81
HP Recovery media	
recovery.....	78
HP Sure Recover.....	79
HP Sure Start.....	95, 101
<b>I</b>	
I/O bracket insert	
spare part number.....	26
illustrated parts catalog.....	17
internal microphones, identifying.....	7
<b>J</b>	
jacks	
audio-out (headphone)/audio-in	
(microphone) combo.....	6
<b>K</b>	
keyboard	
product description.....	3
keyboard with top cover	
spare part numbers.....	74
keys	
esc.....	12
fn.....	12
Windows.....	12
<b>L</b>	
labels	
Bluetooth.....	13
regulatory.....	13
serial number.....	13
service.....	13
wireless certification.....	13
WLAN.....	13
left side components.....	6
lights	
AC adapter and battery.....	6
battery.....	6
camera.....	7
caps lock.....	10
fn lock.....	10
microphone mute.....	10
power.....	10
privacy key.....	10
lights, mute.....	10

<b>M</b>	
memory	
nonvolatile.....	95
volatile.....	95
memory module	
illustrated.....	22
product description.....	1
spare part number.....	22
memory modules	
removal.....	37
spare part numbers.....	37
microphone	
product description.....	2
microphone mute light, identifying.....	10
model name.....	1
mute light, identifying.....	10
<b>N</b>	
nonvolatile memory.....	95
<b>O</b>	
operating system, product description	
.....	3
<b>P</b>	
packaging guidelines.....	29, 33
Plastics Kit	
spare part number.....	26
pointing device, product description..	3
ports	
HDMI.....	5
product description.....	2
USB SuperSpeed.....	6
USB SuperSpeed port with HP	
Sleep and Charge.....	6
USB Type-C power connector and	
SuperSpeed port.....	5
power button, identifying.....	11, 12
power connector	
identifying.....	6
identifying USB Type-C.....	5
power connector cable	
illustrated.....	21
removal.....	50
spare part number.....	21, 50
power cord	
requirements for all countries..	103
requirements for specific countries	
and regions.....	103
set requirements.....	103
power cords, spare part numbers....	26
power lights.....	10

power requirements, product	
description.....	3
primary storage	
product description.....	1
privacy key light.....	10
processor	
product description.....	1
product description	
audio.....	2
chipset.....	1
display panel.....	1
hard drive.....	1
keyboard.....	3
memory module.....	1
microphone.....	2
operating system.....	3
pointing device.....	3
ports.....	2
power requirements.....	3
primary storage.....	1
processors.....	1
product name.....	1
security.....	3
sensors.....	3
serviceability.....	4
solid-state drive.....	1
video.....	2
wireless.....	2
product name.....	1
product name and number, computer.	
.....	13
<b>R</b>	
recovery.....	77, 78
discs.....	78
media.....	78
USB flash drive.....	78
recovery media.....	77
creating using HP Cloud Recovery	
Download Tool.....	77
creating using Windows tools.....	77
regulatory information	
regulatory label.....	13
wireless certification labels.....	13
Remote HP PC Hardware Diagnostics	
UEFI settings	
customizing.....	85
using.....	85
removal and replacement	
procedures.....	35, 43
solid-state drive.....	40
removing personal data from volatile	
system memory.....	95
restoring.....	77

restoring and recovery methods..... 78  
 right side components..... 5  
 RTC battery  
   illustrated..... 22  
   removal..... 48  
   spare part number..... 22, 48

## S

Screw Kit, spare part number..... 26  
 security cable slot, identifying..... 6  
 security, product description..... 3  
 sensors  
   product description..... 3  
 serial number, computer..... 13  
 service labels, locating..... 13  
 serviceability, product description..... 4  
 setup utility  
   navigating and selecting..... 87  
   restoring factory settings..... 88  
 SIM card insert  
   spare part number..... 26  
 SIM card slot, identifying..... 5  
 SIM card, correct size..... 15  
 SIM card, inserting..... 15  
 slots  
   security cable..... 6  
   SIM card..... 5  
 solid-state drive  
   illustrated..... 22  
   product description..... 1  
   removal and replacement..... 40  
   spare part numbers..... 22  
   specifications..... 92, 93  
 spare part country codes..... 74  
 speaker  
   removal..... 49  
   spare part number..... 49  
 speakers  
   illustrated..... 21  
   spare part number..... 21  
 speakers, identifying..... 11  
 special keys, using..... 12  
 specifications  
   computer..... 91  
   display..... 91, 92  
   hard drive..... 91  
   solid-state drive..... 92, 93  
 static electricity..... 29, 30  
 Sure Start  
   using..... 90  
 system board  
   illustrated..... 21  
   removal..... 56  
   spare part numbers..... 21, 56

system memory, removing personal  
   data from volatile..... 95  
 system restore..... 78  
 system restore point, creating..... 77

## T

top cover/keyboard  
   illustrated..... 18-20  
   spare part numbers..... 18-20  
 touchpad  
   illustrated..... 22  
   removal..... 53  
   settings..... 8  
   spare part number..... 22, 53  
 touchpad buttons  
   identifying..... 9  
 touchpad zone, identifying..... 9  
 TPM settings..... 90  
 transporting guidelines..... 29, 33  
 traveling with the computer..... 13

## U

USB board  
   illustrated..... 22  
   removal..... 51  
   spare part number..... 22, 51  
 USB SuperSpeed port with HP Sleep  
   and Charge, identifying..... 6  
 USB SuperSpeed port, identifying..... 6  
 USB Type-C power connector and  
   SuperSpeed port, identifying..... 5

## V

vents, identifying..... 13  
 video, product description..... 2

## W

Windows  
   backup..... 77  
   recovery media..... 77  
   system restore point..... 77  
 Windows key, identifying..... 12  
 Windows tools, using..... 77  
 wireless antennas  
   illustrated..... 23  
   spare part number..... 23  
 wireless antennas, identifying..... 8  
 wireless certification label..... 13  
 wireless, product description..... 2  
 WLAN antennas, identifying..... 8  
 WLAN device..... 13  
 WLAN label..... 13

WLAN module  
   illustrated..... 23  
   removal..... 45  
   spare part numbers..... 23, 45  
 workstation guidelines..... 29  
 WWAN antennas, identifying..... 8  
 WWAN insulator  
   spare part number..... 26  
 WWAN module  
   illustrated..... 23  
   removal..... 46  
   spare part number..... 23, 46