



Maintenance and Service Guide

SUMMARY

This guide provides information about spare parts, removal and replacement of parts, security, backing up, and more.

© Copyright 2021 HP Development Company, L.P.

AMD and Radeon are trademarks of Advanced Micro Devices, Inc. Bluetooth is a trademark owned by its proprietor and used by HP Inc. under license. Chrome, Chrome OS, Chromebook, Google, and Google Drive are trademarks of Google LLC. SDHC, SDXC, and microSD are trademarks or registered trademarks of SD-3C LLC. Microsoft and Windows are either registered trademarks or trademarks of Microsoft Corporation in the United States and/or other countries. USB Type-C and USB-C are registered trademarks of USB Implementers Forum.

The information contained herein is subject to change without notice. The only warranties for HP products and services are set forth in the express warranty statements accompanying such products and services. Nothing herein should be construed as constituting an additional warranty. HP shall not be liable for technical or editorial errors or omissions contained herein.

First Edition: March 2021

Document Part Number: M47125-001

Product notice

This guide describes features that are common to most models. Some features may not be available on your computer.

Software terms

By installing, copying, downloading, or otherwise using any software product preinstalled on this computer, you agree to be bound by the terms of the HP End User License Agreement (EULA). If you do not accept these license terms, your sole remedy is to return the entire unused product (hardware and software) within 14 days for a full refund subject to the refund policy of your seller.

For any further information or to request a full refund of the price of the computer, please contact your seller.

Safety warning notice

Reduce the possibility of heat-related injuries or of overheating the computer by following the practices described.

⚠ WARNING! To reduce the possibility of heat-related injuries or of overheating the computer, do not place the computer directly on your lap or obstruct the computer air vents. Use the computer only on a hard, flat surface. Do not allow another hard surface, such as an adjoining optional printer, or a soft surface, such as pillows or rugs or clothing, to block airflow. Also, do not allow the AC adapter to come into contact with the skin or a soft surface, such as pillows or rugs or clothing, during operation. The computer and the AC adapter comply with the user-accessible surface temperature limits defined by applicable safety standards.

Table of contents

1 Product description	1
2 Components	3
Right	3
Left	4
Display	5
Keyboard area	6
Touchpad	6
Speakers	6
Special keys	7
Labels	8
3 Illustrated parts catalog	10
Computer major components	10
Display assembly subcomponents	11
Cables	13
Miscellaneous parts	13
4 Removal and replacement procedures preliminary requirements	15
Tools required	15
Service considerations	15
Plastic parts	15
Cables and connectors	15
Drive handling	15
Electrostatic discharge information	16
Generating static electricity	16
Preventing electrostatic damage to equipment	17
Personal grounding methods and equipment	17
Grounding the work area	18
Recommended materials and equipment	18
Cleaning your computer	19
Enabling HP Easy Clean (select products only)	19
Removing dirt and debris from your computer	19
Cleaning your computer with a disinfectant	20
Caring for wood veneer (select products only)	21
Packaging and transporting guidelines	21

Accessing support information	21
5 Removal and replacement procedures for authorized service provider parts	23
Component replacement procedures	23
Preparation for disassembly	23
Bottom cover	23
Battery	24
WLAN module	26
Speakers	27
Touchpad	28
USB board	29
Heat sink	30
System board	31
Display assembly	34
Keyboard with top cover	40
6 Backing up, resetting, and recovering	42
Backing up	42
Resetting	42
Recovering	42
Installing the Chromebook Recovery Utility	43
Creating recovery media	43
Recovering the Chrome operating system	43
Setting up your computer after a reset or recovery	44
Erasing and reformatting the recovery media	44
7 Specifications	45
Computer specifications	45
Display specifications	45
8 Power cord set requirements	47
Requirements for all countries	47
Requirements for specific countries and regions	47
9 Recycling	49
Index	50

1 Product description

This table provides detailed product information.

Table 1-1 Product components and their descriptions

Category	Description
Product Name	HP Chromebook™ 14a Model numbers: 14a-nd0xxx, 14az-nd000
Processor	AMD® 3015e (1.2 GHz, turbo up to 2.3 GHz, 5 MB L2 + L3 cache, dual core, 6 W)
Graphics	Internal graphics AMD Radeon™ Graphics Supports HD Decode, DX12, and HDMI
Display	35.6 cm (14.0 in), WLED, antiglare, eDP, narrow bezel, 45% NTSC, narrow bezel Full high definition (FHD) (1920 × 1080), UWVA, nontouch FHD, touch-on panel (TOP), UWVA High definition (HD) (1366 × 768), SVA, nontouch HD, touch-on panel (TOP), SVA
Memory	Onboard, nonupgradeable DDR4-1600 Supports the following configurations: <ul style="list-style-type: none">• 8 GB• 4 GB
Primary storage	On-board embedded MultiMedia Controller (eMMC v5.0) configuration 128 GB 64 GB 32 GB
Audio and video	Dual speakers HP Wide Vision Camera (720p) Dual-array microphone with appropriate software, echo cancellation, and noise suppression
Wireless	Integrated wireless options with dual antennas Realtek RTL8822CE 802.11b/g/n/a/ac (2 × 2) MU-MIMO supported and Bluetooth® 5.0
Media card reader	HP Multi-Format Digital Media Card Reader Supports microSD™, SDHC™, SDXC™ Push-push insertion/removal

Table 1-1 Product components and their descriptions (continued)

Category	Description
Ports	Audio-out (headphone)/audio-in (microphone) combo jack <hr/> (2) USB 3.2 Gen1 Type C - Supports power delivery - Supports data transfer - Supports DisplayPort 1.4 out up to 3840 × 2160 @ 60 Hz - Supports HDMI 2.0 out up to 3840 × 2160 @ 60 Hz with HDCP 2.2 out through adapter <hr/> (1) USB 3.2 Gen1 Type-A
Keyboard/pointing devices	Google® Keyboard with clickpad <hr/> Full size, island style, backlit <hr/> Full size, island style, not backlit
Power requirements	Battery <hr/> 2 cell, 47 Whr, lithium-ion polymer <hr/> Long life <hr/> Fast charge <hr/> AC adapter, USB Type-C® <hr/> 45 W, nPFC, straight <hr/> Power cord <hr/> C5, 1 m (3.3 ft)
Security	H1 Secure Microcontroller
Operating system	Google Chrome™
Serviceability	End user replaceable parts <hr/> AC adapter

2 Components

Your computer features top-rated components. This chapter provides details about your components, where they are located, and how they work.

Right

Use the illustration and table to identify the components on the right side of the computer.

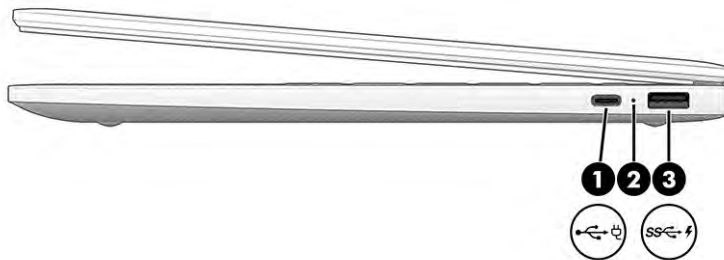



Table 2-1 Right-side components and their descriptions

Component	Description
(1) 	<p>USB Type-C® power connector and port</p> <p>Connects an AC adapter that has a USB Type-C connector, supplying power to the computer and, if needed, charging the computer battery.</p> <p>– and –</p> <p>Connects a USB device, provides data transfer, and (for select products) charges small devices (such as a smartphone) when the computer is on or in Sleep mode.</p> <p>NOTE: Use a standard USB Type-C charging cable or cable adapter (purchased separately) when charging a small external device.</p> <p>– and –</p> <p>Connects a display device that has a USB Type-C connector, providing DisplayPort™ output.</p>
(2)	<p>AC adapter and battery light</p> <ul style="list-style-type: none"> • White: The AC adapter is connected and the battery is fully charged. • Amber: The AC adapter is connected and the battery is charging. • Off: The battery is not charging.
(3) 	<p>USB SuperSpeed port with HP Sleep and Charge</p> <p>Connects a USB device, provides high-speed data transfer, and charges small devices (such as a smartphone), even when the computer is off.</p> <p>NOTE: Use a standard USB Type-A charging cable or cable adapter (purchased separately) when charging a small external device.</p>

Left

Use the illustration and table to identify the components on the left side of the computer.

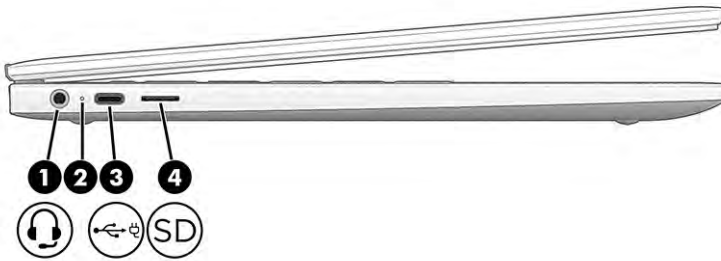

Table 2-2 Left-side components and their descriptions



Component	Description
(1)  Audio-out (headphone)/Audio-in (microphone) combo jack	<p>Connects optional powered stereo speakers, headphones, earbuds, a headset, or a television audio cable. Also connects an optional headset microphone. This jack does not support optional standalone microphones.</p> <p>WARNING! To reduce the risk of personal injury, adjust the volume before putting on headphones, earbuds, or a headset. For additional safety information, see the <i>Regulatory, Safety, and Environmental Notices</i>.</p> <p>NOTE: When a device is connected to the jack, the computer speakers are disabled.</p>
(2) AC adapter and battery light	<ul style="list-style-type: none">• White: The AC adapter is connected and the battery is fully charged.• Amber: The AC adapter is connected and the battery is charging.• Off: The battery is not charging.
(3)  USB Type-C® power connector and port	<p>Connects an AC adapter that has a USB Type-C connector, supplying power to the computer and, if needed, charging the computer battery.</p> <p>– and –</p> <p>Connects a USB device, provides data transfer, and (for select products) charges small devices (such as a smartphone) when the computer is on or in Sleep mode.</p> <p>NOTE: Use a standard USB Type-C charging cable or cable adapter (purchased separately) when charging a small external device.</p> <p>– and –</p> <p>Connects a display device that has a USB Type-C connector, providing DisplayPort™ output.</p>
(4)  Memory card reader	<p>Reads optional memory cards that store, manage, share, or access information.</p> <p>To insert a card:</p> <ol style="list-style-type: none">1. Hold the card label-side up, with the connectors facing the computer.

Table 2-2 Left-side components and their descriptions (continued)

Component	Description
	<p>2. Insert the card into the memory card reader, and then press in on the card until it is firmly seated.</p> <p>To remove a card:</p> <p>▲ Press in on the card, and then remove it from the memory card reader.</p>

Display

Use the illustration and table to identify the components on the display.

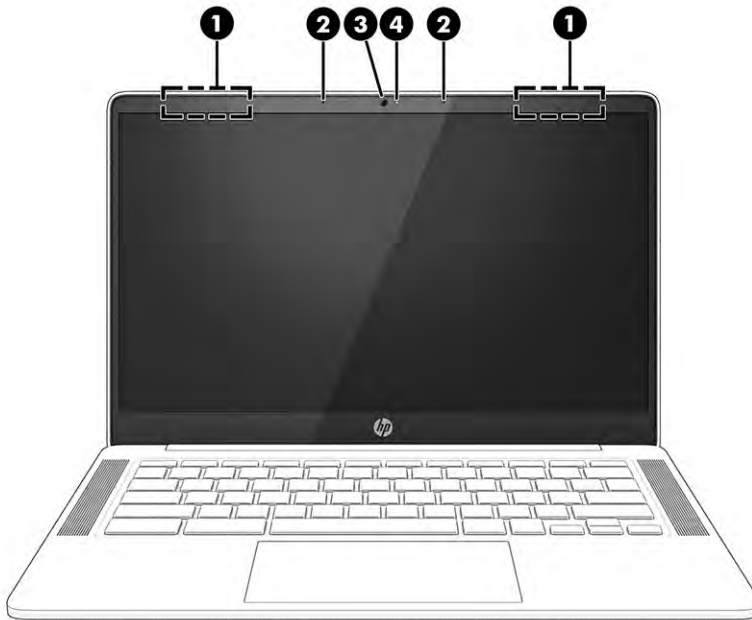

Table 2-3 Display components and their descriptions

Component	Description
(1) WLAN antennas*	Send and receive wireless signals to communicate with wireless local area networks (WLANs).
(2) Internal microphones (2)	Record sound.
(3) Camera	Allows you to video chat, record video, and record still images. NOTE: Camera functions vary depending on the camera hardware and software installed on your product.
(4) Camera light	On (white): The camera is in use. Off: The camera is turned off by the software.

*The antennas are not visible from the outside of the computer. For optimal transmission, keep the areas immediately around the antennas free from obstructions.

For wireless regulatory notices, see the section of the *Regulatory, Safety, and Environmental Notices* that applies to your country or region.

Keyboard area

Keyboards can vary by language.

Touchpad

The touchpad settings and components are described here.

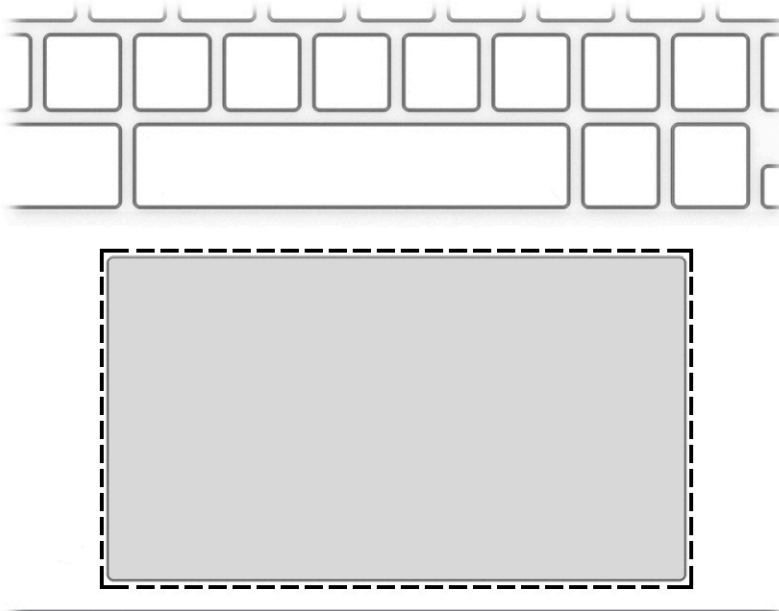

Table 2-4 Touchpad component and description

Component	Description
Touchpad zone	Reads your finger gestures to move the pointer or activate items on the screen.

Speakers

Use the illustration and table to identify the speakers.

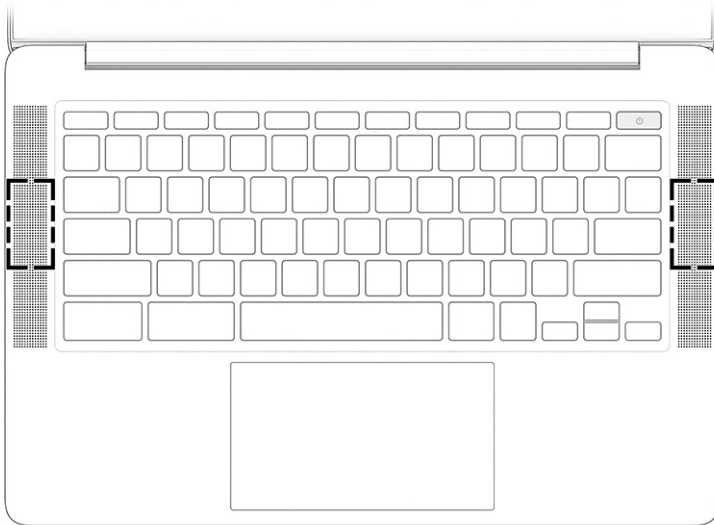

Table 2-5 Speakers and its description

Component	Description
Speakers (2)	Produce sound.

Special keys

Use the illustration and table to locate the special keys.

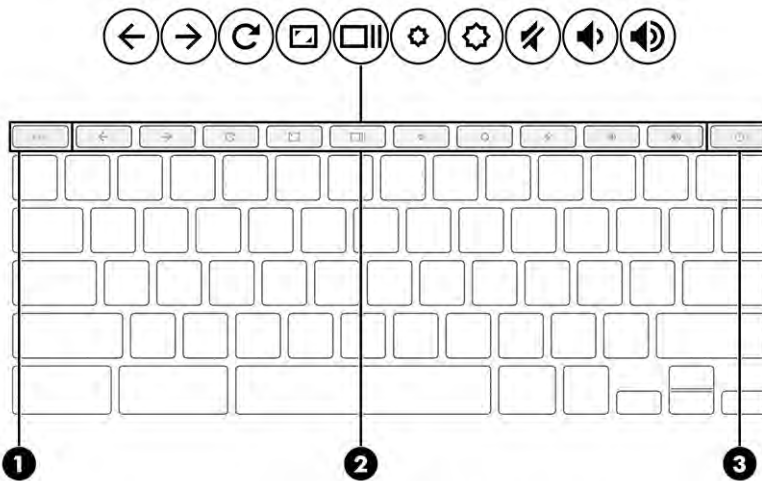

Table 2-6 Special keys and their descriptions

Component	Description
(1) <code>esc</code> key	Activates certain computer functions when pressed in combination with other keys, such as <code>tab</code> or <code>shift</code> .
(2) Action keys	Execute frequently used system functions.
(3)  Power key	<ul style="list-style-type: none"> When the computer is off, press the key briefly to turn on the computer. When the computer is in the Sleep state, press the key briefly to exit Sleep (select products only).

Table 2-6 Special keys and their descriptions (continued)

Component	Description
	<ul style="list-style-type: none"> When the computer is in Hibernation, press the key briefly to exit Hibernation. <p>IMPORTANT: Pressing and holding down the power key results in the loss of unsaved information.</p> <p>If the computer has stopped responding and shutdown procedures are ineffective, press and hold the power key for at least 10 seconds to turn off the computer.</p>

Labels

The labels affixed to the computer provide information that you might need when you troubleshoot system problems or travel internationally with the computer. Labels can be in paper form or imprinted on the product.

IMPORTANT: Check the following locations for the labels described in this section: the bottom of the computer, inside the battery bay, under the service door, on the back of the display, or on the bottom of a tablet kickstand.

- Service label—Provides important information to identify your computer. When contacting support, you may be asked for the serial number, the product number, or the model number. Locate this information before you contact support.

Your service label will resemble one of the following examples. Refer to the illustration that most closely matches the service label on your computer.

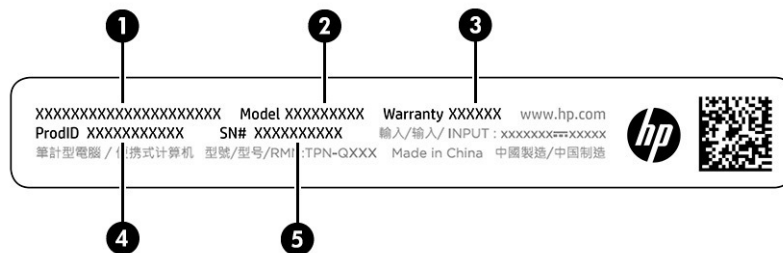

Table 2-7 Service label components

Component
(1) HP product name
(2) Model number
(3) Warranty period
(4) Product ID
(5) Serial number

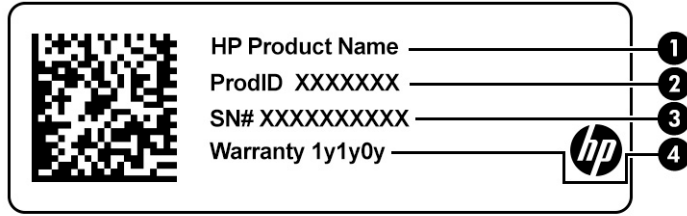

Table 2-8 Service label components

Component	
(1)	HP product name
(2)	Product ID
(3)	Serial number
(4)	Warranty period

- Regulatory labels—Provide regulatory information about the computer.
- Wireless certification labels—Provide information about optional wireless devices and the approval markings for the countries or regions in which the devices have been approved for use.

3 Illustrated parts catalog

Use this table to determine the spare parts that are available for the computer.

Computer major components

To identify the computer major components, use this illustration and table.

NOTE: HP continually improves and changes product parts. For complete and current information about supported parts for your computer, go to <http://partsurfer.hp.com>, select your country or region, and then follow the on-screen instructions.

NOTE: Details about your computer, including model, serial number, product key, and length of warranty, are on the service tag at the bottom of your computer.

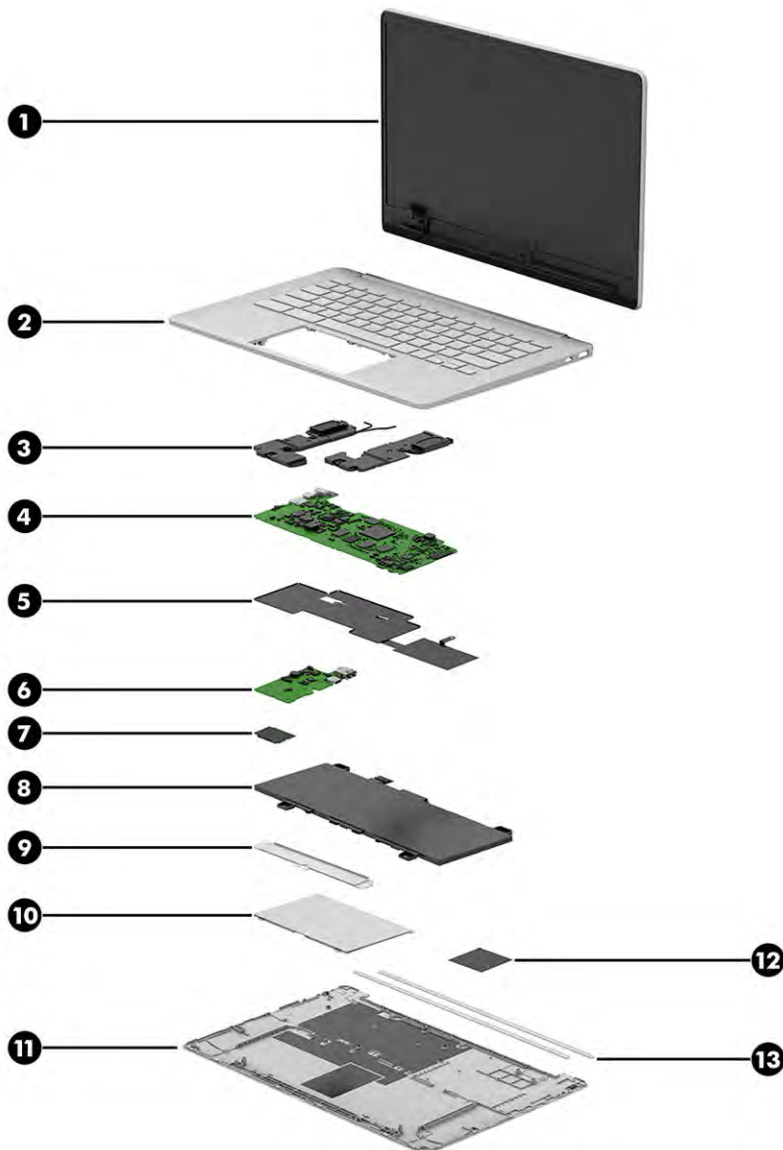

Table 3-1 Computer major component descriptions and part numbers

Item	Component	Spare part number
(1)	Display assembly NOTE: Display assemblies are spared only at the subcomponent level.	
(2)	Top cover with keyboard	
	Natural silver top cover, jet black keyboard, not backlit	M49649-xx1
	Natural silver top cover, jet black keyboard, backlit	M49650-xx1
	Natural silver top cover, snow white keyboard, backlit	M49651-xx1
	Natural silver top cover, snow white keyboard, not backlit	M49652-xx1
	Natural silver top cover, natural silver keyboard, backlit	M52662-xx1
	Natural silver top cover, natural silver keyboard, not backlit	M52663-xx1
(3)	Speaker Kit	M49659-001
(4)	System board (includes integrated AMD 3015e processor, system memory, and eMMC storage; includes replacement thermal material)	
	8 GB of system memory, 128 GB of eMMC storage	M49647-001
	8 GB of system memory, 64 GB of eMMC storage	M49648-001
	4 GB of system memory, 64 GB of eMMC storage	M74332-001
	4 GB of system memory, 32 GB of eMMC storage	M49646-001
(5)	Heat sink (includes replacement thermal material)	M49660-001
(6)	USB board NOTE: USB cables are available as spare part number L73309-001 (high speed) and L73310-001 (low speed).	M49657-001
(7)	WLAN module (Realtek RTL8822CE 802.11b/g/n/a/ac (2 × 2) MU-MIMO supported and Bluetooth 5.0)	L44796-005
(8)	Battery (2 cell, 47 Whr)	L75783-005
(9)	Touchpad bracket	not available as a spare part
(10)	Touchpad NOTE: The touchpad cable is available as spare part number L91527-001.	M49661-001
(11)	Bottom cover	M49658-001
(12)	Thermal pad	M47379-001
(13)	Rubber feet	L91524-001
	Screw covers (not illustrated)	L91525-001

Display assembly subcomponents

To identify the display assembly subcomponents, use this illustration and table.

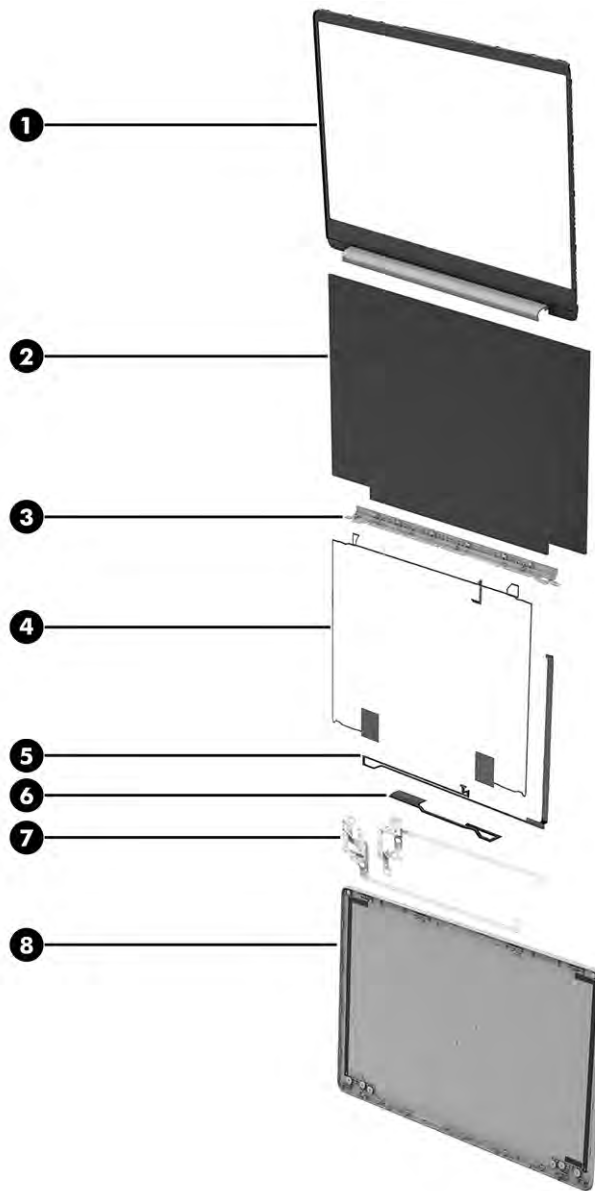

Table 3-2 Display component descriptions and part numbers

Item	Component	Spare part number
(1)	Display bezel	
	Jet black	M49662-001
	Mineral silver	M52664-001
(2)	Display panel	M49289-001
	FHD, nontouch	M49653-001
	FHD, touch-on panel (TOP)	M49654-001
	HD, nontouch	M49655-001
	HD, touch-on panel (TOP)	M49656-001

Table 3-2 Display component descriptions and part numbers (continued)

Item	Component	Spare part number
(3)	Display bracket	not available as a spare part
(4)	Wireless antennas	L91533-001
(5)	Camera cable	M74216-001
(6)	Display cable	
	Nontouch	M74214-001
	Touch-on panel (TOP)	M74215-001
(7)	Hinges (left and right)	L91537-001
(8)	Display back cover (includes wireless antennas and bracket)	
	Forest teal	L91529-001
	Mineral silver	L91530-001
	Ceramic white	L91531-001
	Camera module (not illustrated)	M49663-001

Cables

To identify the cables, use this illustration and table.

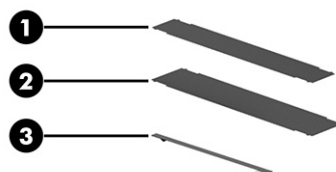
**Table 3-3 Cable descriptions and part number**

Item	Component	Spare part number
(1)	USB board cable	L73309-001
(2)	USB board cable	L73310-001
(3)	Touchpad cable	L91527-001

Miscellaneous parts

To identify the miscellaneous parts, use this table.

Table 3-4 Miscellaneous part descriptions and part numbers

Component	Spare part number
AC adapter, USB Type-C (45 W, nPFC, 1.8 m [6.0 ft])	L43407-001
Screw Kit	M49664-001

Table 3-4 Miscellaneous part descriptions and part numbers (continued)

Component	Spare part number
Miscellaneous Kit (includes WLAN module protective tape)	M49665-001
Rubber Kit (included touchpad bracket rubber with protective tape and hinge cap rubber)	M47238-001
Power cord (C5, 1.0 m [3.3 ft])	
Australia	L19358-001
Denmark	L19360-001
Europe (Austria, Belgium, Finland, France, Germany, the Netherlands, Norway, and Sweden)	L19361-001
India	L19363-001
Japan	L19365-001
North America	L19367-001
The United Kingdom	L19373-001

4 Removal and replacement procedures preliminary requirements

Use this information to properly prepare to disassemble and reassemble the computer.

Tools required

You need the following tools to complete the removal and replacement procedures:

- Nonconductive, nonmarking pry tool
- Magnetic Phillips P1 screwdriver

Service considerations

The following sections include some of the considerations that you must keep in mind during disassembly and assembly procedures.

 **NOTE:** As you remove each subassembly from the computer, place the subassembly (and all accompanying screws) away from the work area to prevent damage.

Plastic parts

Using excessive force during disassembly and reassembly can damage plastic parts.

Cables and connectors

Handle cables with extreme care to avoid damage.

 **IMPORTANT:** When servicing the computer, be sure that cables are placed in their proper locations during the reassembly process. Improper cable placement can damage the computer.

Apply only the tension required to unseat or seat the cables during removal and insertion. Handle cables by the connector whenever possible. In all cases, avoid bending, twisting, or tearing cables. Be sure that cables are routed so that they cannot be caught or snagged as you remove or replace parts. Handle flex cables with extreme care; these cables tear easily.

Drive handling

Note the following guidelines when handling drives.



IMPORTANT: Drives are fragile components. Handle them with care. To prevent damage to the computer, damage to a drive, or loss of information, observe these precautions:

Before removing or inserting a hard drive, shut down the computer. If you are unsure whether the computer is off or in Hibernation, turn the computer on, and then shut it down through the operating system.

Before handling a drive, be sure that you are discharged of static electricity. While handling a drive, avoid touching the connector.

Before removing an optical drive, be sure that a disc is not in the drive, and be sure that the optical drive tray is closed.

Handle drives on surfaces covered with at least 2.54 cm (1 inch) of shock-proof foam.

Avoid dropping drives from any height onto any surface.

After removing a hard drive or an optical drive, place it in a static-proof bag.

Avoid exposing an internal hard drive to products that have magnetic fields, such as monitors or speakers.

Avoid exposing a drive to temperature extremes or liquids.

If a drive must be mailed, place the drive in a bubble pack mailer or other suitable form of protective packaging, and label the package “FRAGILE.”

Electrostatic discharge information

A sudden discharge of static electricity from your finger or other conductor can destroy static-sensitive devices or microcircuitry. Often the spark is neither felt nor heard, but damage occurs. An electronic device exposed to electrostatic discharge (ESD) might not appear to be affected at all and can work perfectly throughout a normal cycle. The device might function normally for a while, but it has been degraded in the internal layers, reducing its life expectancy.

Networks built into many integrated circuits provide some protection, but in many cases, the discharge contains enough power to alter device parameters or melt silicon junctions.



IMPORTANT: To prevent damage to the device when you remove or install internal components, observe these precautions:

Keep components in their electrostatic-safe containers until you are ready to install them.

Before touching an electronic component, discharge static electricity by using the guidelines described [Personal grounding methods and equipment on page 17](#).

Avoid touching pins, leads, and circuitry. Handle electronic components as little as possible.

If you remove a component, place it in an electrostatic-safe container.

Generating static electricity

Follow these static electricity guidelines.

- Different activities generate different amounts of static electricity.
- Static electricity increases as humidity decreases.

Table 4-1 Static electricity occurrence based on activity and humidity

Event	Relative humidity		
	55%	40%	10%
Walking across carpet	7,500 V	15,000 V	35,000 V

Table 4-1 Static electricity occurrence based on activity and humidity (continued)

	Relative humidity		
Walking across vinyl floor	3,000 V	5,000 V	12,000 V
Motions of bench worker	400 V	800 V	6,000 V
Removing DIPs (dual in-line packages) from plastic tube	400 V	700 V	2,000 V
Removing DIPs from vinyl tray	2,000 V	4,000 V	11,500 V
Removing DIPs from polystyrene foam	3,500 V	5,000 V	14,500 V
Removing bubble pack from PCB (printed circuit board)	7,000 V	20,000 V	26,500 V
Packing PCBs in foam-lined box	5,000 V	11,000 V	21,000 V

Multiple electric components can be packaged together in plastic tubes, trays, or polystyrene foam.

 **NOTE:** As little as 700 V can degrade a product.

Preventing electrostatic damage to equipment

Many electronic components are sensitive to ESD. Circuitry design and structure determine the degree of sensitivity. The following packaging and grounding precautions are necessary to prevent static electricity damage to electronic components.

- To avoid hand contact, transport products in static-safe containers such as tubes, bags, or boxes.
- Protect all electrostatic parts and assemblies with conductive or approved containers or packaging.
- Keep electrostatic-sensitive parts in their containers until they arrive at static-free stations.
- Place items on a grounded surface before removing them from their container.
- Always be properly grounded when touching a sensitive component or assembly.
- Avoid contact with pins, leads, or circuitry.
- Place reusable electrostatic-sensitive parts from assemblies in protective packaging or conductive foam.

Personal grounding methods and equipment

Using certain equipment can prevent static electricity damage to electronic components.

- **Wrist straps** are flexible straps with a maximum of 1 M Ω \pm 10% resistance in the ground cords. To provide proper ground, a strap must be worn snug against bare skin. The ground cord must be connected and fit snugly into the banana plug connector on the grounding mat or workstation.
- **Heel straps/Toe straps/Boot straps** can be used at standing workstations and are compatible with most types of shoes or boots. On conductive floors or dissipative floor mats, use them on both feet with a maximum of 1 M Ω \pm 10% resistance between the operator and ground.

Table 4-2 Static shielding protection levels

Static shielding protection levels	
Method	Voltage
Antistatic plastic	1,500

Table 4-2 Static shielding protection levels (continued)

Static shielding protection levels	
Carbon-loaded plastic	7,500
Metallized laminate	15,000

Grounding the work area

To prevent static damage at the work area, follow these precautions.

- Cover the work surface with approved static-dissipative material.
- Use a wrist strap connected to a properly grounded work surface and use properly grounded tools and equipment.
- Use static-dissipative mats, foot straps, or air ionizers to give added protection.
- Handle electrostatic sensitive components, parts, and assemblies by the case or PCB laminate. Handle them only at static-free work areas.
- Turn off power and input signals before inserting and removing connectors or test equipment.
- Use fixtures made of static-safe materials when fixtures must directly contact dissipative surfaces.
- Keep the work area free of nonconductive materials, such as ordinary plastic assembly aids and polystyrene foam.
- Use conductive field service tools, such as cutters, screwdrivers, and vacuums.
- Avoid contact with pins, leads, or circuitry.

Recommended materials and equipment

HP recommends certain materials and equipment to prevent static electricity.

- Antistatic tape
- Antistatic smocks, aprons, or sleeve protectors
- Conductive bins and other assembly or soldering aids
- Conductive foam
- Conductive tabletop workstations with ground cord of $1\text{ M}\Omega \pm 10\%$ resistance
- Static-dissipative table or floor mats with hard tie to ground
- Field service kits
- Static awareness labels
- Wrist straps and footwear straps providing $1\text{ M}\Omega \pm 10\%$ resistance
- Material handling packages
- Conductive plastic bags
- Conductive plastic tubes
- Conductive tote boxes
- Opaque shielding bags

- Transparent metallized shielding bags
- Transparent shielding tubes

Cleaning your computer

Cleaning your computer regularly removes dirt and debris so that your device continues to operate at its best. Use the following information to safely clean the external surfaces of your computer.

Enabling HP Easy Clean (select products only)

HP Easy Clean helps you to avoid accidental input while you clean the computer surfaces. This software disables devices such as the keyboard, touch screen, and touchpad for a preset amount of time so that you can clean all computer surfaces.

1. Start HP Easy Clean in one of the following ways:
 - Select the **Start** menu, and then select **HP Easy Clean**.
– or –
 - Select the **HP Easy Clean** icon in the taskbar.
– or –
 - Select **Start**, and then select the **HP Easy Clean** tile.
2. Now that your device is disabled for a short period, see [Removing dirt and debris from your computer on page 19](#) for the recommended steps to clean the high-touch, external surfaces on your computer. After you remove the dirt and debris, you can also clean the surfaces with a disinfectant. See [Cleaning your computer with a disinfectant on page 20](#) for guidelines to help prevent the spread of harmful bacteria and viruses.

Removing dirt and debris from your computer

Here are the recommended steps to clean dirt and debris from your computer.

For computers with wood veneer, see [Caring for wood veneer \(select products only\) on page 21](#).

1. Wear disposable gloves made of latex (or nitrile gloves, if you are latex-sensitive) when cleaning the surfaces.
2. Turn off your device and unplug the power cord and other connected external devices. Remove any installed batteries from items such as wireless keyboards.

 **CAUTION:** To prevent electric shock or damage to components, never clean a product while it is turned on or plugged in.

3. Moisten a microfiber cloth with water. The cloth should be moist, but not dripping wet.

 **IMPORTANT:** To avoid damaging the surface, avoid abrasive cloths, towels, and paper towels.

4. Wipe the exterior of the product gently with the moistened cloth.

 **IMPORTANT:** Keep liquids away from the product. Avoid getting moisture in any openings. If liquid makes its way inside your HP product, it can cause damage to the product. Do not spray liquids directly on the product. Do not use aerosol sprays, solvents, abrasives, or cleaners containing hydrogen peroxide or bleach that might damage the finish.

5. Start with the display (if applicable). Wipe carefully in one direction, and move from the top of the display to the bottom. Finish with any flexible cables, like power cord, keyboard cable, and USB cables.
6. Be sure that surfaces have completely air-dried before turning the device on after cleaning.
7. Discard the gloves after each cleaning. Clean your hands immediately after you remove the gloves.

See [Cleaning your computer with a disinfectant on page 20](#) for recommended steps to clean the high-touch, external surfaces on your computer to help prevent the spread of harmful bacteria and viruses.

Cleaning your computer with a disinfectant

The World Health Organization (WHO) recommends cleaning surfaces, followed by disinfection, as a best practice for preventing the spread of viral respiratory illnesses and harmful bacteria.

After cleaning the external surfaces of your computer using the steps in [Removing dirt and debris from your computer on page 19](#), [Caring for wood veneer \(select products only\) on page 21](#), or both, you might also choose to clean the surfaces with a disinfectant. A disinfectant that is within HP's cleaning guidelines is an alcohol solution consisting of 70% isopropyl alcohol and 30% water. This solution is also known as rubbing alcohol and is sold in most stores.

Follow these steps when disinfecting high-touch, external surfaces on your computer:

1. Wear disposable gloves made of latex (or nitrile gloves, if you are latex-sensitive) when cleaning the surfaces.
2. Turn off your device and unplug the power cord and other connected external devices. Remove any installed batteries from items such as wireless keyboards.

 **CAUTION:** To prevent electric shock or damage to components, never clean a product while it is turned on or plugged in.

3. Moisten a microfiber cloth with a mixture of 70% isopropyl alcohol and 30% water. The cloth should be moist, but not dripping wet.

 **CAUTION:** Do not use any of the following chemicals or any solutions that contain them, including spray-based surface cleaners: bleach, peroxides (including hydrogen peroxide), acetone, ammonia, ethyl alcohol, methylene chloride, or any petroleum-based materials, such as gasoline, paint thinner, benzene, or toluene.

 **IMPORTANT:** To avoid damaging the surface, avoid abrasive cloths, towels, and paper towels.

4. Wipe the exterior of the product gently with the moistened cloth.

 **IMPORTANT:** Keep liquids away from the product. Avoid getting moisture in any openings. If liquid makes its way inside your HP product, it can cause damage to the product. Do not spray liquids directly on the product. Do not use aerosol sprays, solvents, abrasives, or cleaners containing hydrogen peroxide or bleach that might damage the finish.

5. Start with the display (if applicable). Wipe carefully in one direction, and move from the top of the display to the bottom. Finish with any flexible cables, like power cord, keyboard cable, and USB cables.
6. Be sure that surfaces have completely air-dried before turning the device on after cleaning.
7. Discard the gloves after each cleaning. Clean your hands immediately after you remove the gloves.

Caring for wood veneer (select products only)

Your product might feature high-quality wood veneer. As with all natural wood products, proper care is important for best results over the life of the product. Because of the nature of natural wood, you might see unique variations in the grain pattern or subtle variations in color, which are normal.

- Clean the wood with a dry, static-free microfiber cloth or chamois.
- Avoid cleaning products containing substances such as ammonia, methylene chloride, acetone, turpentine, or other petroleum-based solvents.
- Do not expose the wood to sun or moisture for long periods of time.
- If the wood becomes wet, dry it by dabbing with an absorbent, lint-free cloth.
- Avoid contact with any substance that might dye or discolor the wood.
- Avoid contact with sharp objects or rough surfaces that might scratch the wood.

See [Removing dirt and debris from your computer on page 19](#) for the recommended steps to clean the high-touch, external surfaces on your computer. After you remove the dirt and debris, you can also clean the surfaces with a disinfectant. See [Cleaning your computer with a disinfectant on page 20](#) for sanitizing guidelines to help prevent the spread of harmful bacteria and viruses.

Packaging and transporting guidelines

Follow these grounding guidelines when packaging and transporting equipment.

- To avoid hand contact, transport products in static-safe tubes, bags, or boxes.
- Protect ESD-sensitive parts and assemblies with conductive or approved containers or packaging.
- Keep ESD-sensitive parts in their containers until the parts arrive at static-free workstations.
- Place items on a grounded surface before removing items from their containers.
- Always be properly grounded when touching a component or assembly.
- Store reusable ESD-sensitive parts from assemblies in protective packaging or nonconductive foam.
- Use transporters and conveyors made of antistatic belts and roller bushings. Be sure that mechanized equipment used for moving materials is wired to ground and that proper materials are selected to avoid static charging. When grounding is not possible, use an ionizer to dissipate electric charges.

Accessing support information

Use this information to find the HP support that you need.

Table 4-3 Support information locations

Service consideration	Path to access information
Records of reported failure incidents stored on the computer	Windows: Pre-operating system failures are logged in the BIOS Event Log. To view the BIOS Event Log: <ol style="list-style-type: none">1. Press the power button.2. Immediately and repeatedly press <code>esc</code> when the power button light turns white.

Table 4-3 Support information locations (continued)

Service consideration	Path to access information
	<p>NOTE: If you do not press <code>esc</code> at the appropriate time, you must restart the computer and again repeatedly press <code>esc</code> when the power button light turns white to access the utility.</p> <ol style="list-style-type: none"> Press <code>f10</code> to enter the BIOS setup. (On commercial products) Under the Main tab, select BIOS event log, and then select View BIOS Event Log. <p>- or -</p> <p>(On consumer products) Under the Main tab, select System Log.</p> <p>Post operating system failures are logged in the Event Viewer.</p> <ol style="list-style-type: none"> Turn on the computer and allow the operating system to open. Click the search icon  in the taskbar. Type <code>Event Viewer</code>, and then press <code>enter</code>. Select the log from the left panel. Details display in the right panel. <p>Chrome:</p> <ol style="list-style-type: none"> Go to support.google.com/chrome. Search <code>collect Chrome device logs</code>.
Technical bulletins	<p>To locate technical bulletins:</p> <ol style="list-style-type: none"> Go to www.hp.com. Place the cursor over Problem solving to display more options. Select Support & Troubleshooting. Type the serial number, product number, or product name to go to the product support page. Select Advisories to view technical bulletins.
Repair professionals	<p>To locate repair professionals:</p> <ol style="list-style-type: none"> Go to www.hp.com. Place the cursor over Support resources to display more options. Select Authorized service providers.
Component and diagnosis information, failure detection, and required action	<p>To locate diagnosis information and actions:</p> <ol style="list-style-type: none"> Go to http://www.hp.com/go/techcenter/pcdiags. Select Get Support. Near the bottom of the window, select Notebook PCs, and then select your location.

5 Removal and replacement procedures for authorized service provider parts

This chapter provides removal and replacement procedures for authorized service provider parts.

 **IMPORTANT:** Components described in this chapter should be accessed only by an authorized service provider. Accessing these parts can damage the computer or void the warranty.

 **NOTE:** Details about your computer, including model, serial number, product key, and length of warranty, are on the service tag at the bottom of your computer.

Component replacement procedures

To remove and replace computer components, use these procedures.

 **NOTE:** HP continually improves and changes product parts. For complete and current information about supported parts for your computer, go to <http://partsurfer.hp.com>, select your country or region, and then follow the on-screen instructions.

You must remove, replace, or loosen as many as 46 screws when you service the parts described in this chapter. Make special note of each screw size and location during removal and replacement.

Preparation for disassembly

To remove and replace computer components, use these procedures.

See [Removal and replacement procedures preliminary requirements on page 15](#) for initial safety procedures.

1. Turn off the computer. If you are unsure whether the computer is off or in Hibernation, turn the computer on, and then shut it down through the operating system.
2. Disconnect the power from the computer by unplugging the power cord from the computer.
3. Disconnect all external devices from the computer.

Bottom cover

To remove the bottom cover, use this procedure and illustration.

Table 5-1 Bottom cover description and part number

Description	Spare part number
Bottom cover	M49658-001
Rubber feet	L91524-001
Screw covers	L91525-001

Before removing the bottom cover, prepare the computer for disassembly ([Preparation for disassembly on page 23](#)).

Remove the bottom cover:

1. Remove the two rubber feet from the bottom of the computer **(1)**.
2. Remove the eight Phillips M2.0 × 5.0 screws **(2)** from the bottom of the computer.

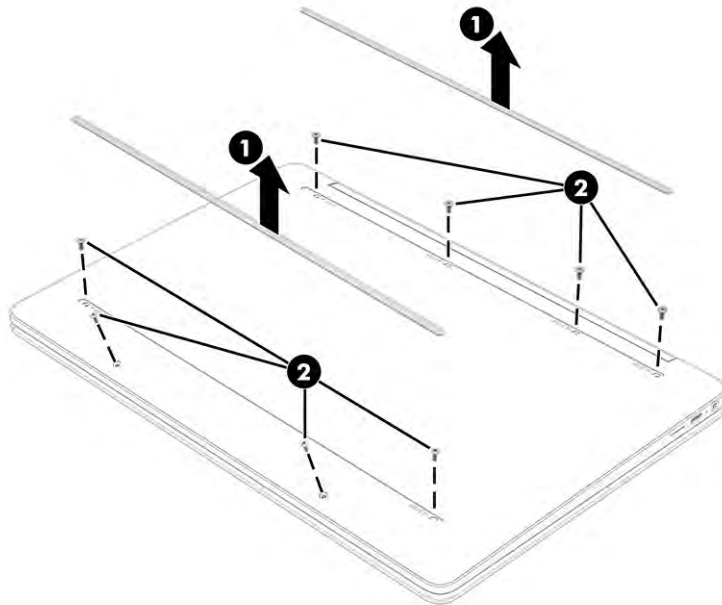

3. Starting near the hinge, use a tool and work around the edges to release the bottom cover from the computer **(1)**.
4. Remove the bottom cover from the computer **(2)**.



To replace the bottom cover, reverse the removal procedures.

Battery

To remove the battery, use this procedure and illustration.

Table 5-2 Battery description and part number

Description	Spare part number
Battery (2 cell, 47 Whr)	L75783-005

 **WARNING!** To avoid personal injury and damage to the product:

- Do *not* puncture, twist, or crack the battery.
- Do *not* cause an external puncture or rupture to the battery. They can cause a short inside the battery, which can result in battery thermal runaway.
- Do *not* handle or touch the battery enclosure with sharp objects such as tweezers or pliers, which might puncture the battery.
- Do *not* compress or squeeze the battery case with tools or heavy objects stacked on top of the case. These actions can apply undue force on the battery.
- Do *not* touch the connectors with any metallic surface or object, such as metal tools, screws, or coins, which can cause shorting across the connectors.

Before removing the battery, follow these steps:

1. Prepare the computer for disassembly (see [Preparation for disassembly on page 23](#)).
2. Remove the bottom cover (see [Bottom cover on page 23](#)).

 **WARNING!** To reduce potential safety issues, use only the user-replaceable battery provided with the computer, a replacement battery provided by HP, or a compatible battery purchased from HP.

 **IMPORTANT:** Removing a battery that is the sole power source for the computer can cause loss of information. To prevent loss of information, save your work or shut down the computer through Windows before you remove the battery.

Remove the battery:

1. Lift the tape off the system board connector **(1)**, and then disconnect the battery cable from the system board **(2)**.
2. Remove the speaker cable from the clips along the bottom of the battery **(3)**.
3. Remove the six Phillips M2.0 × 3.5 screws **(4)** that secure the battery to the computer.

4. Remove the battery from the computer **(5)**.

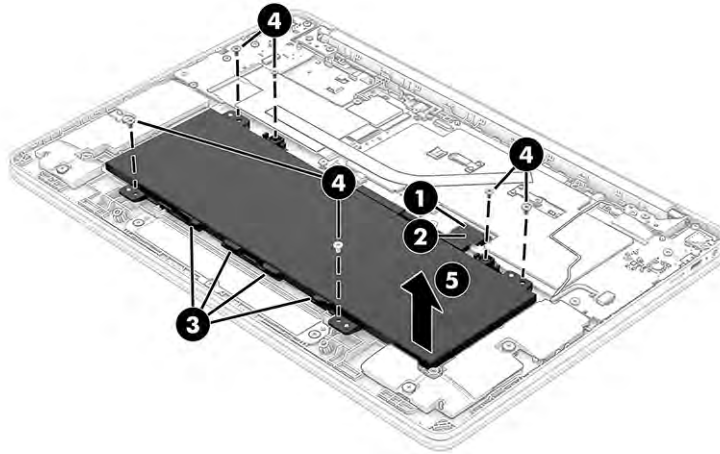

To replace the battery, reverse the removal procedures.

WLAN module

To remove the WLAN module, use this procedure and illustration.

Table 5-3 WLAN module descriptions and part numbers

Description	Spare part number
Realtek RTL8822CE 802.11b/g/n/a/ac (2 × 2) MU-MIMO supported and Bluetooth 5.0	L44796-005

 **IMPORTANT:** To prevent an unresponsive system, replace the wireless module only with a wireless module authorized for use in the computer by the governmental agency that regulates wireless devices in your country or region. If you replace the module and then receive a warning message, remove the module to restore device functionality, and then contact technical support.

Before removing the WLAN module, follow these steps:

1. Prepare the computer for disassembly (see [Preparation for disassembly on page 23](#)).
2. Remove the bottom cover (see [Bottom cover on page 23](#)).
3. Disconnect the battery cable from the system board (see [Battery on page 24](#)).

Remove the WLAN module:

1. Remove the clear plastic piece from the WLAN module **(1)**.
2. Carefully disconnect the antenna cables from the module **(2)**.

 **NOTE:** The #1 white WLAN antenna cable connects to the WLAN module #1 Main terminal. The #2 black WLAN antenna cable connects to the WLAN module #1 Aux terminal.

3. Remove the Phillips M2.0 × 2.5 screw **(3)**.

4. Remove the WLAN module from the socket (4).

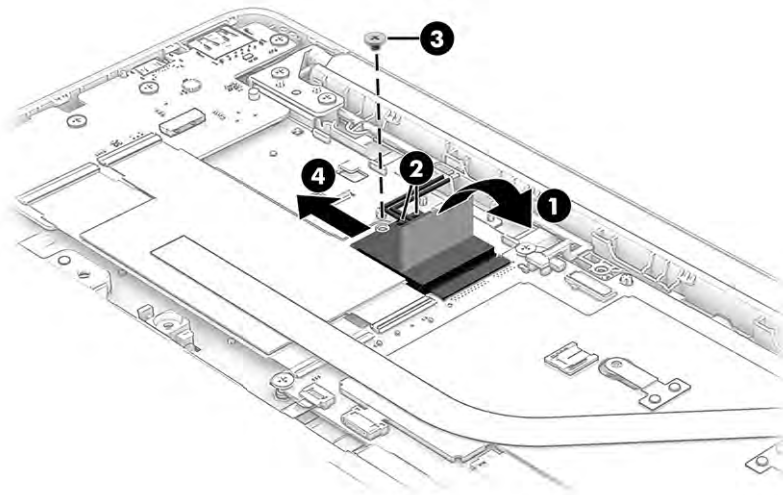

5. If the WLAN antenna is not connected to the terminal on the WLAN module, install a protective sleeve on the antenna connector, as shown in the following illustration.

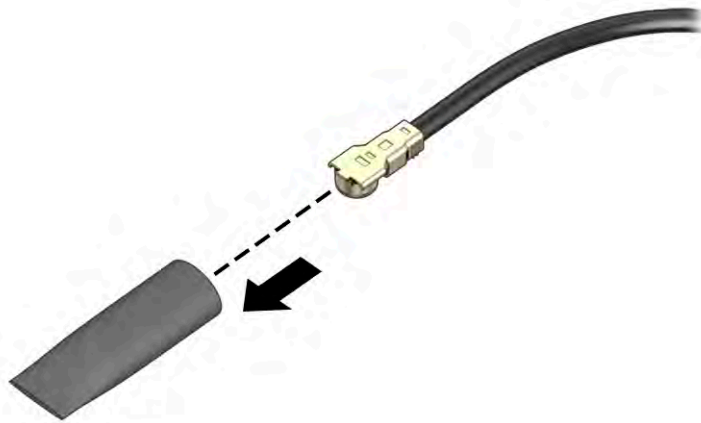

Reverse this procedure to install the WLAN module.

Speakers

To remove the speakers, use this procedure and illustration.

Table 5-4 Speaker description and part number

Description	Spare part number
Speaker Kit	M49659-001

Before removing the speakers, follow these steps:

1. Prepare the computer for disassembly (see [Preparation for disassembly on page 23](#)).
2. Remove the bottom cover (see [Bottom cover on page 23](#)).
3. Remove the battery (see [Battery on page 24](#)).

Remove the speakers:

1. Disconnect the speaker cable from the system board **(1)**.
2. Remove the two Phillips M2.0 × 4.8 screws **(2)** that secure each speaker to the computer.
3. Remove the speakers from the computer **(3)**.

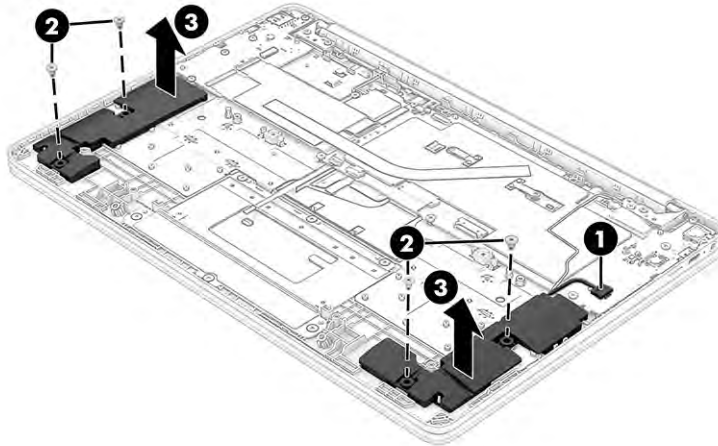

Reverse this procedure to install the speakers.

Touchpad

To remove the touchpad, use this procedure and illustration.

Table 5-5 Touchpad description and part number

Description	Spare part number
Touchpad	M49661-001
Touchpad cable	L91527-001

Before removing the touchpad, follow these steps:

1. Prepare the computer for disassembly (see [Preparation for disassembly on page 23](#)).
2. Remove the bottom cover (see [Bottom cover on page 23](#)).
3. Remove the battery (see [Battery on page 24](#)).

Remove the touchpad:

1. Remove the three Phillips M2.0 × 2.0 screws **(1)** that secure the touchpad bracket to the computer.

2. Remove the bracket from the computer (2).

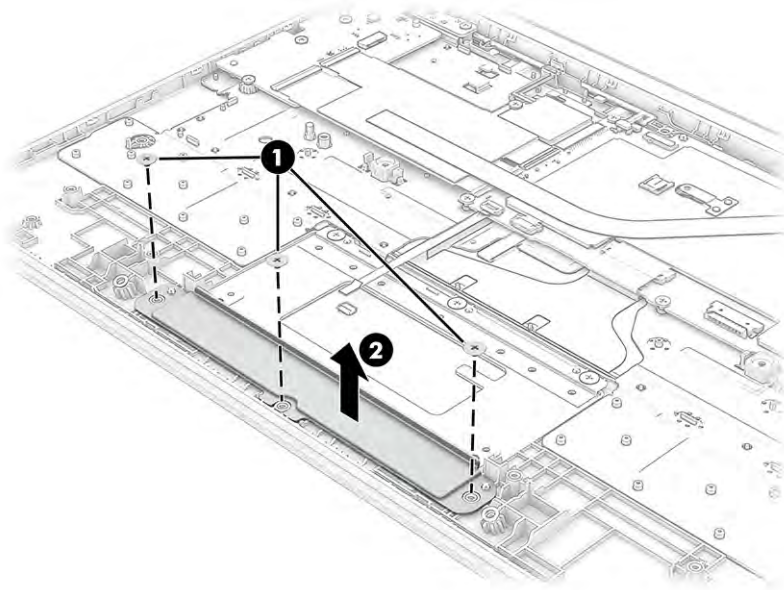

3. Disconnect the cable from the ZIF connector on the touchpad (1).
4. Remove the protective shielding from the top of the touchpad to expose the screws (2).
5. Remove the three broadhead Phillips M2.0 × 2.0 screws (3) that secure the touchpad to the computer.
6. Remove the touchpad from the computer (4).

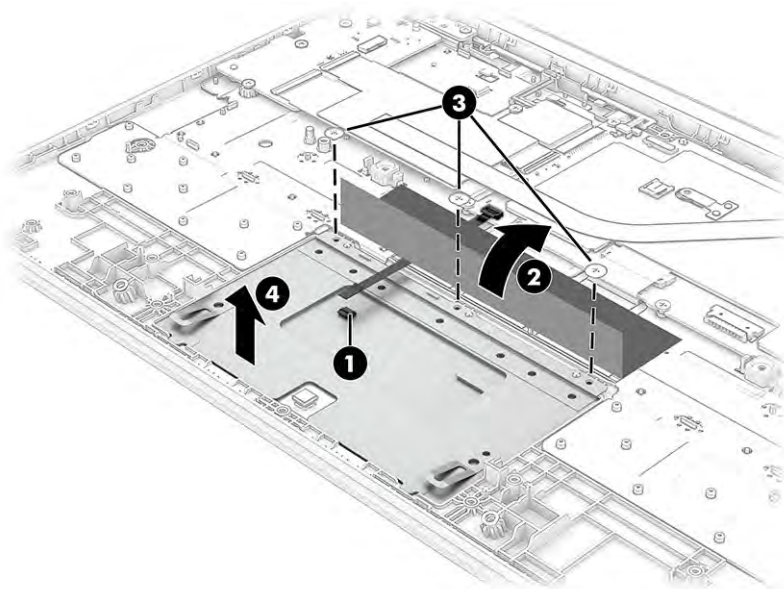

Reverse this procedure to install the touchpad.

USB board

To remove the USB board, use this procedure and illustration.

Table 5-6 USB board description and part number

Description	Spare part number
USB board	M49657-001
USB board cable, high speed	L73309-001
USB board cable, low speed	L73310-001

Before removing the USB board, follow these steps:

1. Prepare the computer for disassembly (see [Preparation for disassembly on page 23](#)).
2. Remove the bottom cover (see [Bottom cover on page 23](#)).
3. Disconnect the battery cable from the system board (see [Battery on page 24](#)).

Remove the USB board:

1. Disconnect the two cables from the ZIF connectors on the USB board (1).
2. Remove the four Phillips M2.0 × 3.0 screws (2) that secure the board to the computer.
3. Remove the board from the computer (3).

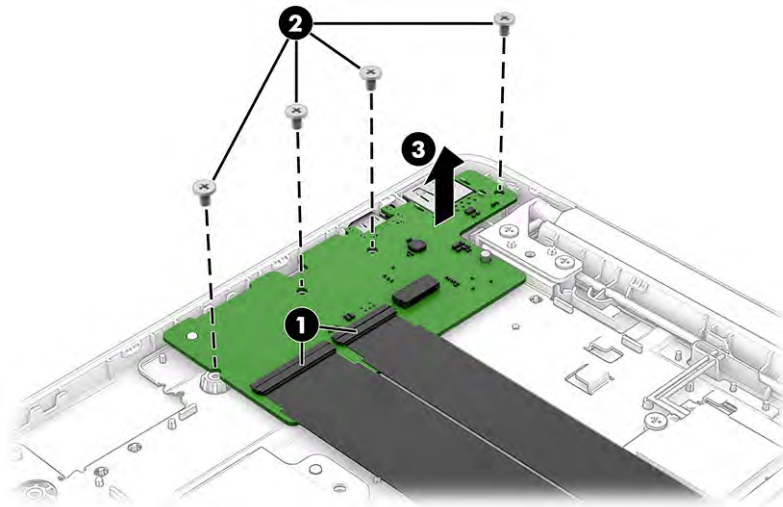

Reverse this procedure to install the USB board.

Heat sink

To remove the heat sink, use these procedures and illustrations.

Table 5-7 Heat sink descriptions and part numbers

Description	Spare part number
Heat sink	M49660-001

Before removing the heat sink, follow these steps:

1. Prepare the computer for disassembly (see [Preparation for disassembly on page 23](#)).
2. Remove the bottom cover (see [Bottom cover on page 23](#)).
3. Disconnect the battery cable from the system board (see [Battery on page 24](#)).

Remove the heat sink:

1. Remove the two Phillips M2.0 × 2.0 screws (1), and then remove the heat sink from the computer (2).

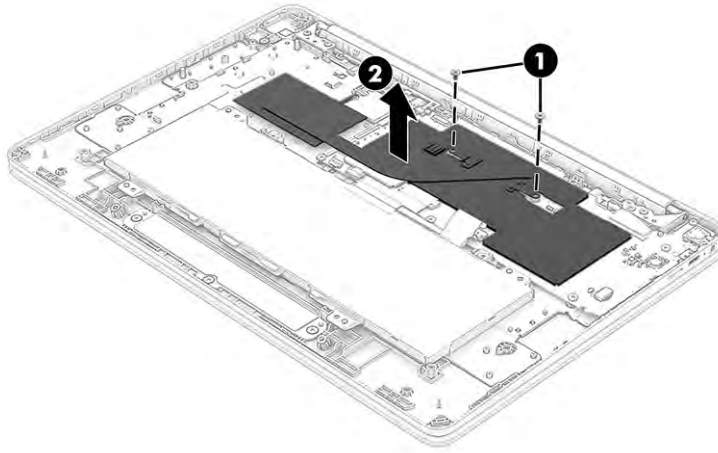

2. Thoroughly clean the thermal material from the surfaces of the heat sink and the system board components each time the heat sink is removed. Replacement thermal material is included with the heat sink and system board spare part kits. The following illustration shows the replacement thermal material locations.

Thermal paste is used on the heat sink (1) and one system board component (2).

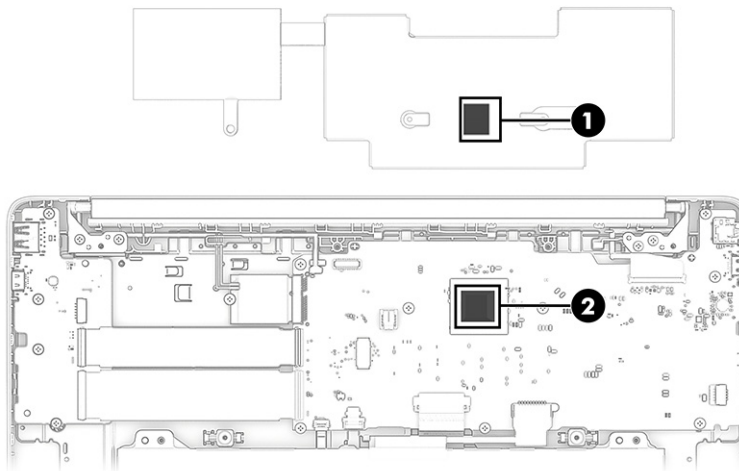

Reverse this procedure to install the heat sink.

System board

To remove the system board, use these procedures and illustrations.

Table 5-8 System board descriptions and part numbers

Description	Spare part number
AMD 3015e processor, 8 GB of system memory, 128 GB of eMMC storage	M49647-001
AMD 3015e processor, 8 GB of system memory, 64 GB of eMMC storage	M49648-001
AMD 3015e processor, 4 GB of system memory, 64 GB of eMMC storage	M74332-001
AMD 3015e processor, 4 GB of system memory, 32 GB of eMMC storage	M49646-001
Thermal pad	M47379-001

Before removing the system board, follow these steps:

1. Prepare the computer for disassembly (see [Preparation for disassembly on page 23](#)).
2. Remove the bottom cover (see [Bottom cover on page 23](#)).

Remove the system board:

1. Disconnect the following cables from the system board:
 - Camera cable **(1)**
 - Display cable **(2)**
 - Speaker cable **(3)**
 - Battery cable **(4)**
 - Keyboard cable (ZIF) **(5)**
 - Keyboard camera cable **(6)**
 - Touchpad cable (ZIF) **(7)**
 - USB board cable (ZIF) **(8)**
 - USB board cable (ZIF) **(9)**

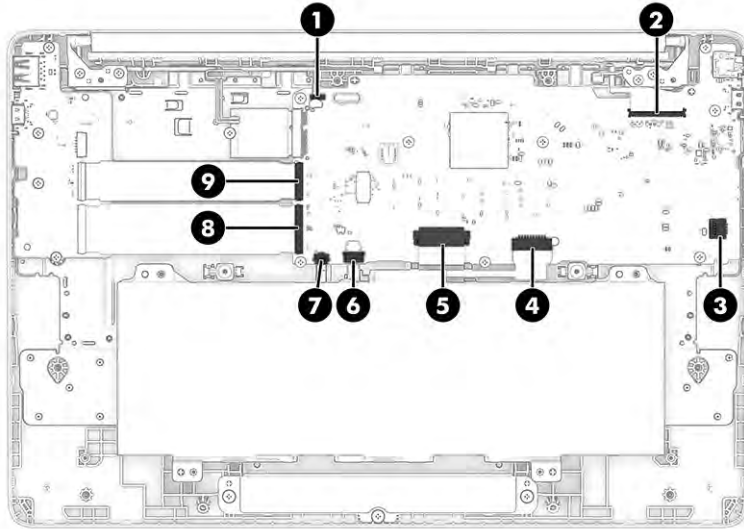

2. Remove the five Phillips M2.0 × 35.0 screws **(1)** that secure the system board to the computer.
3. Lift the side of the system board **(2)**, and then pull the board up and into the computer to remove it **(3)**.

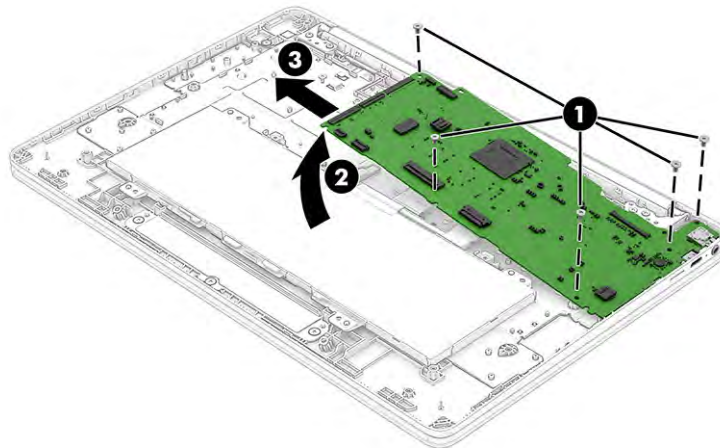

4. When installing a system board, make sure the thermal pad is installed as shown in the following illustration.

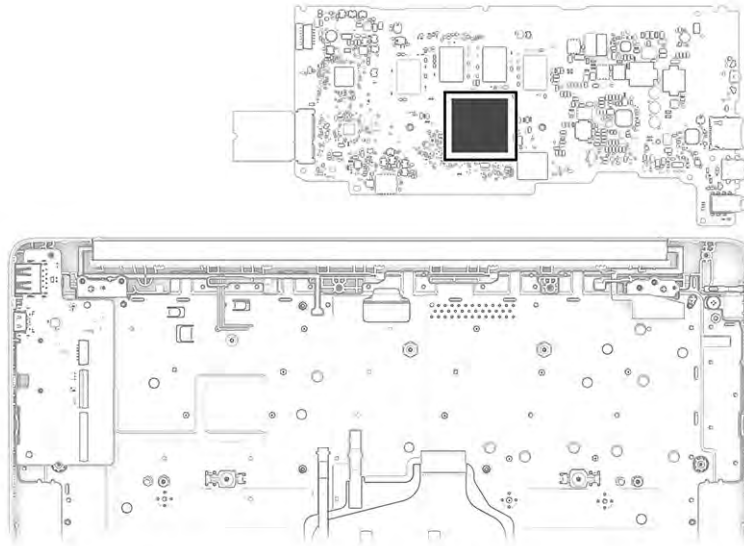

Reverse this procedure to install the system board.

Display assembly

To remove and disassemble the display assembly, use these procedures and illustrations.

Before removing the display panel, follow these steps:

1. Prepare the computer for disassembly (see [Preparation for disassembly on page 23](#)).
2. Remove the bottom cover (see [Bottom cover on page 23](#)).
3. Disconnect the battery cable from the system board (see [Battery on page 24](#)).

Remove the display assembly:

1. Disconnect the antenna cables from the WLAN module **(1)**, and then remove the cables from the clips **(2)**.



NOTE: One antenna cable routes through each hinge.

2. Disconnect the display cable from the system board **(2)**, and then remove the cable from the clips **(3)**.
3. Disconnect the camera cable from the system board **(3)**, and then remove the cable from the clips **(4)**.

4. Disconnect the display cable from the system board (5).

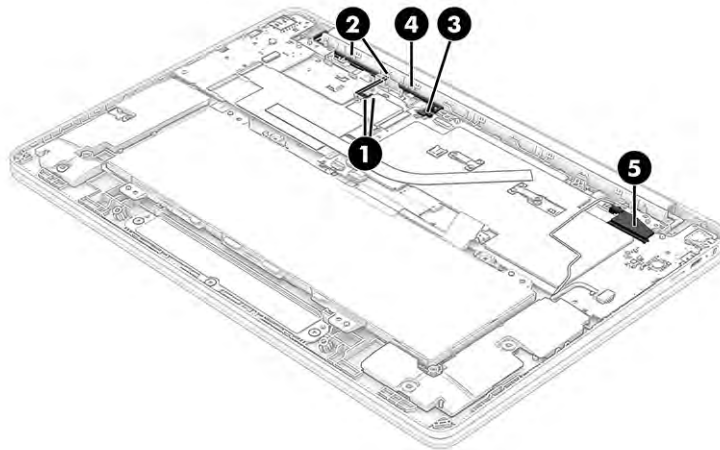

5. Remove the four Phillips M2.5 × 4.5 screws (1) that secure the display to the computer.
6. Open the computer to open the hinges (2).
7. Separate the display from the computer (3).

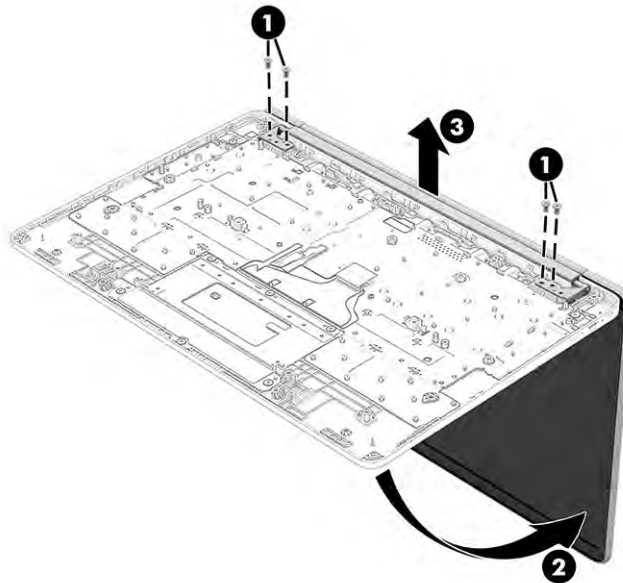

8. If you need to remove the bezel:
 - a. Flex the top (1), the left and right sides (2), and then the bottom of the bezel (3) to release it.
 - b. Remove the bezel from the display (4).

The bezel is available as the spare part number M49662-001 in jet black and M52664-001 in mineral silver.

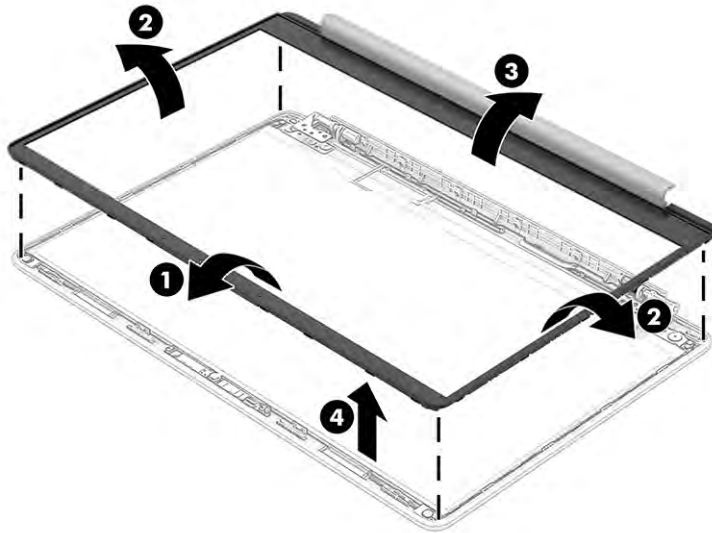

9. If you need to remove the display panel:

- a.** Insert a flat tool on the right and left sides of the panel between the panel and display rear cover to release the panel from the cover **(1)**.
- b.** Rotate the display panel over and place it next to the display rear cover **(2)**.

Display panels are available as the following spare part numbers:

M49653-001: FHD, nontouch

M49654-001: FHD, touch-on panel (TOP)

M49655-001: HD, nontouch

M49656-001: HD, touch-on panel (TOP)

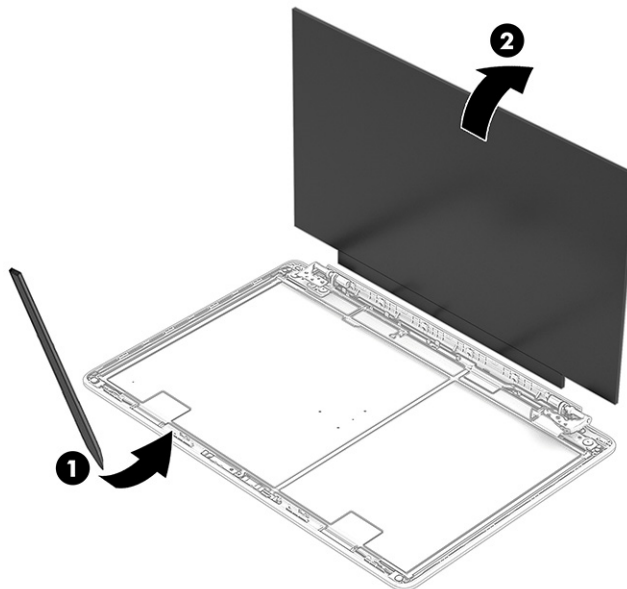

- c. Lift the tape from the connector on the display panel **(1)**, lift the locking lever **(2)**, and then disconnect the cable from the panel **(3)**.

The display cable is available as spare part number M74214-001 for nontouch models and M74215-001 for touch models.

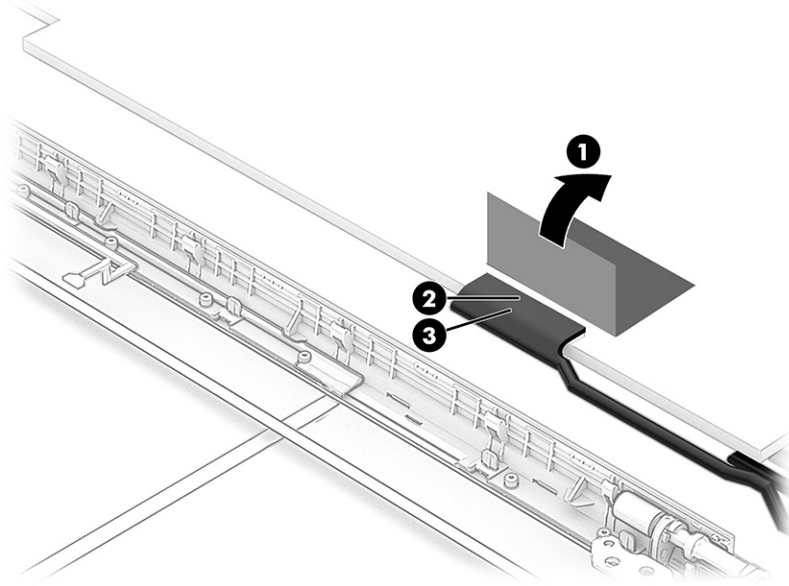

10. If you need to remove the camera module:

- a. Use a flat tool to lift up evenly across the camera module to remove it from the display rear cover **(1)**.
- b. Disconnect the cable from the camera module **(2)**.

The camera module is available as spare part number M74216-001.

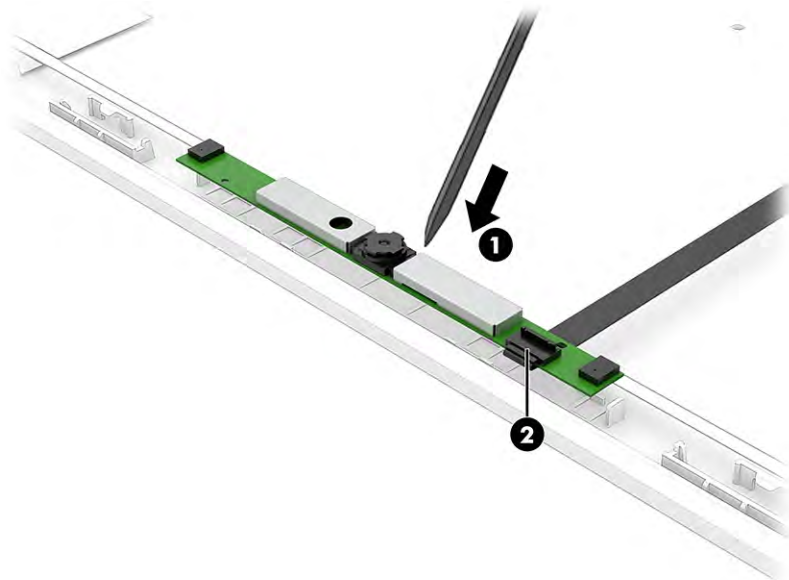

11. If you need to remove the camera cable, remove the cable from the routing along the bottom of the display rear cover (1), and then peel the camera cable off the display rear cover (2). The cable is secured with adhesive.

The camera cable is available as spare part number M47240-001.

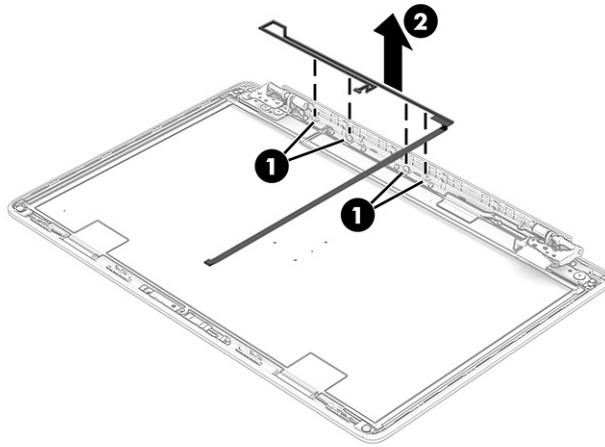

12. If you need to remove the hinges from the display:
 - a. For removal and reinstallation, note the display cable routing around the left hinge.

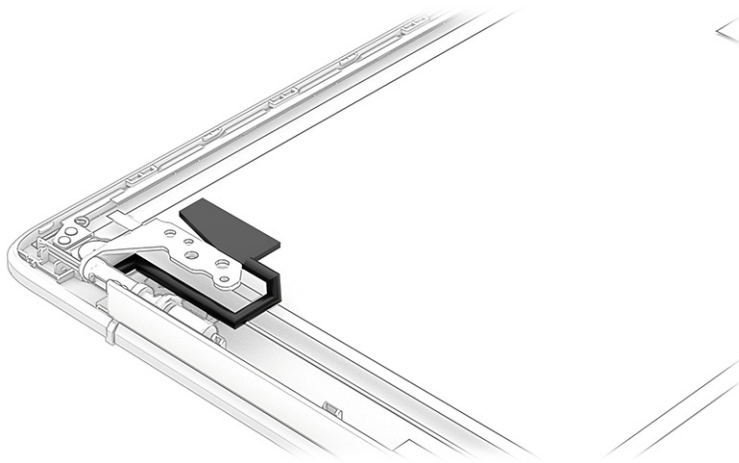

- b.** For removal and reinstallation, note the cable antenna cable routing around the right hinge.

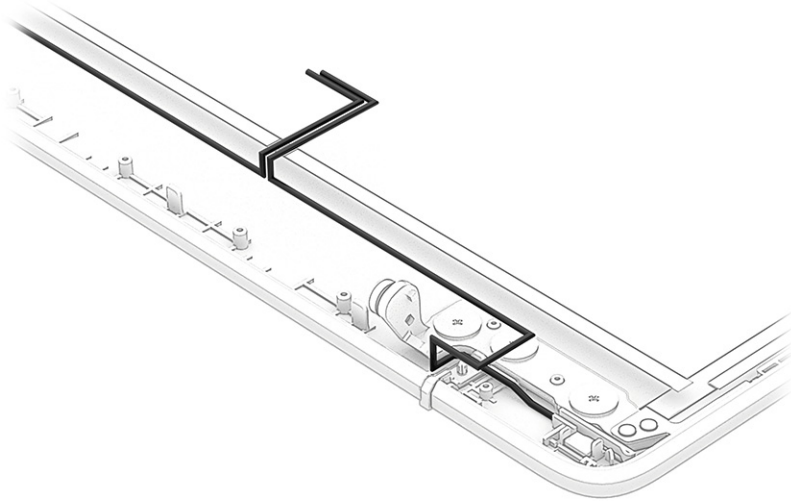

- c.** Remove the Phillips M2.0 × 2.5 screw **(1)** from the top of each hinge bracket.
- d.** Remove the three Phillips M2.5 × 2.8 screws **(2)** from each hinge.
- e.** Remove the hinges from the display rear cover **(3)**.

The display hinges are available as spare part number L91537-001.

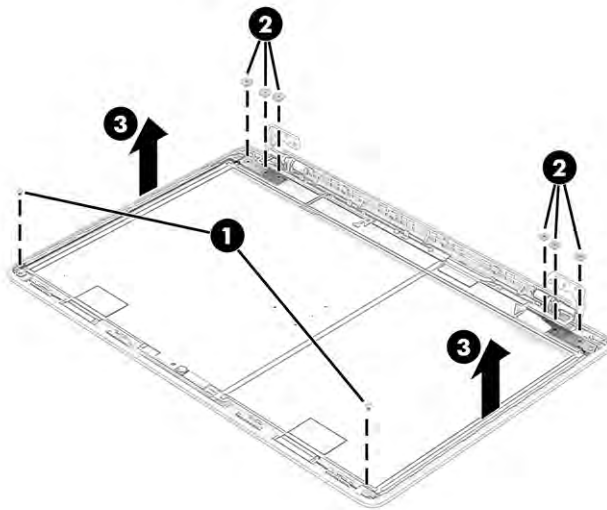

13. You must remove the display bracket to remove the wireless antennas. To remove the bracket, lift it straight up and off the display rear cover.

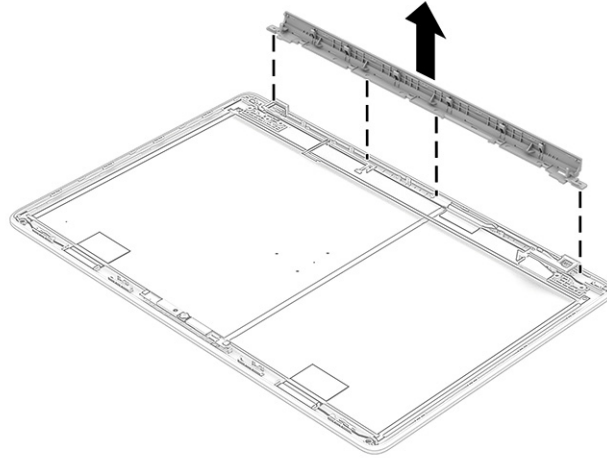

14. If you need to remove the wireless antennas, peel the antennas off the display rear cover, remove the antenna cables from the routing clips along the bottom, left side, and right side of the display rear cover (1), and then remove the antennas and cables (2).

The antennas and cables are available as spare part number L91533-001.

The display rear cover is available as the following spare part numbers:

L91529-001: Forest teal

L91530-001: Mineral silver

L91531-001: Ceramic white

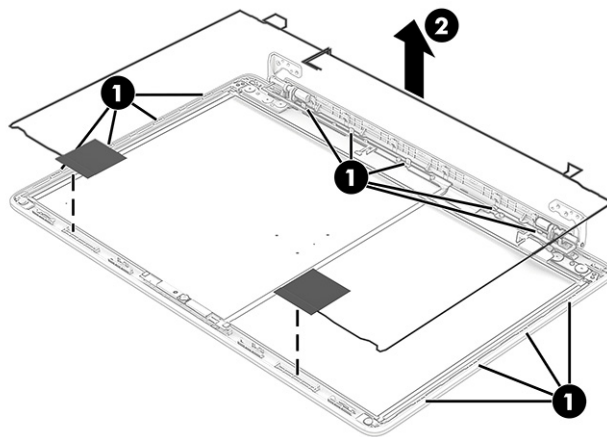

Reverse this procedure to reassemble and replace the display assembly.

Keyboard with top cover

The top cover with keyboard remains after removing all other spare parts from the computer. In this section, the first table provides the main spare part number for the top cover/keyboards. The second table provides the country codes.

Table 5-9 Keyboard with top cover descriptions and part numbers

Description	Spare part number
Natural silver top cover, jet black keyboard, not backlit	M49649-xx1
Natural silver top cover, jet black keyboard, backlit	M49650-xx1
Natural silver top cover, snow white keyboard, backlit	M49651-xx1
Natural silver top cover, snow white keyboard, not backlit	M49652-xx1
Natural silver top cover, natural silver keyboard, backlit	M52662-xx1
Natural silver top cover, natural silver keyboard, not backlit	M52663-xx1

Table 5-10 Spare part country codes

For use in country or region	Spare part number	For use in country or region	Spare part number	For use in country or region	Spare part number
Belgium	-A41	Germany	-041	Spain	-071
Denmark, Finland, and Norway	-DH1	International	-B31	United Kingdom	-031
French Canada	-DB1	Italy	-061	United States	-001
France	-051	Japan	-291		

6 Backing up, resetting, and recovering

This chapter provides information about the standard procedures of backing up your personal data, resetting your computer to original factory conditions, and recovering your operating system with the Chromebook Recovery Utility.

Backing up

You can back up your data to an optional USB flash drive or SD memory card or through Google Drive™.

For detailed information about creating a backup, go to <http://www.support.google.com>.

Resetting

A factory reset erases the information on your computer hard drive, including files in the Downloads folder. Before you reset, back up your files to an optional USB flash drive, to an SD memory card, or through Google Drive. The factory reset will not delete your files at these locations.

You might want to reset your computer in the following circumstances:

- You see the message "Reset this Chrome device."
- You are having problems with your user profile or settings.
- You restarted your computer, and it still doesn't work properly.
- You want to change the owner of your computer.

To reset your computer:

1. Under the **Settings** menu, select **Advanced**.
2. In the **Powerwash** section, select **Powerwash**.
3. Select **Restart**.
4. In the window that appears, select **Powerwash**, and then select **Continue**.
5. Follow the on-screen instructions to reset your computer, and sign in with your Google Account.



NOTE: The account you sign in with after you reset your computer is recognized as the owner account.

6. After you complete the reset, you can set up your computer and check to see whether the problem is fixed.

Recovering

When your Chrome OS™ doesn't work properly, you can perform a recovery. A recovery reinstalls the operating system, software programs, and original factory settings. It deletes locally saved files and saved networks for all accounts. A system recovery does not affect Google Accounts and data synced to Google Drive.



IMPORTANT: Recovery permanently erases everything on your computer hard drive, including your downloaded files. If possible, back up your files before you recover your computer.

 **NOTE:** For more information about performing a system recovery on your computer, go to <http://www.support.google.com>.

Before you begin the recovery process, you need the following prerequisites:

- A USB flash drive or SD memory card with a capacity of 4 GB or greater. All data is erased from this storage device when the recovery media is created, so back up all files from the device before you begin.
- A computer with internet access. You must also have administrative rights to the computer.
- Computer AC adapter. The computer must be plugged into AC power during recovery.
- The “Chrome OS is missing or damaged” screen displaying on your computer. If this message is not already displayed:
 - Turn on the computer, press and hold the `esc+f3` keys, and then press the power button. The computer restarts, and the screen shows the “Chrome OS is missing or damaged” screen.

Installing the Chromebook Recovery Utility

The Chromebook™ Recovery Utility recovers the original operating system and software programs that were installed at the factory. You can install this utility from the Chrome Web Store on any computer.

To install the Chromebook Recovery Utility:

- ▲ Open the Chrome Web Store, search for `chrome recovery`, select **Chromebook Recovery Utility** from the Apps list, and follow the on-screen instructions.

Creating recovery media

You can use recovery media to recover the original operating system and software programs that were installed at the factory.

To create recovery media:

1. Turn on a computer that has internet access.
-
2. Select the **Launcher** icon, and then select **All Apps**.
 3. In the Apps window, select **Recovery**, and then select **Get started**.
 4. Follow the on-screen instructions to create the recovery media.

 **NOTE:** All data and partitions on your recovery media will be deleted. Do not remove the USB flash drive or SD memory card until the process is complete.

Recovering the Chrome operating system

Use these instructions to recover the Chrome operating system on your computer using the recovery media that you created.

1. Disconnect any external devices connected to your computer, plug in the power cord, and then turn on the computer.
2. To enter recovery mode, press and hold `esc+f3`, and then press the power button. When the “Chrome OS is missing or damaged” screen appears, insert the recovery media into your computer. The recovery process begins immediately.
3. Wait while Chrome verifies the integrity of the recovery media.

 **NOTE:** If you need to cancel the recovery during the verification process, press and hold the power button until the computer turns off. Do not disrupt the system recovery process after the verification step is complete.

 **NOTE:** If an error message is displayed, you might need to run the Chrome Recovery Utility again or use a different USB flash drive or SD memory card.

4. When the “System Recovery is complete” message appears, remove the recovery media.
The computer restarts with Chrome OS reinstalled.

Setting up your computer after a reset or recovery

After a reset or recovery is complete, perform the initial setup process.

For details about setting up the computer, go to <http://www.support.google.com>.

Erasing and reformatting the recovery media

When you create recovery media, the USB flash drive or SD memory card is formatted as a recovery tool. After recovery, you must erase the recovery media to reuse your storage device. Follow these steps to use the Chromebook Recovery Utility to erase the recovery media.

1. Select the **Launcher** icon, and then select **All Apps**.
2. In the apps window, select **Recovery**.
3. Select the **Settings** icon, and then select **Erase recovery media**.
4. Select the USB flash drive or SD memory card that you inserted, select **Continue**, and then select **Erase now**.
5. After the recovery media is erased, select **Done** to close the Chromebook Recovery Utility, and then remove the USB flash drive or SD memory card.

The media is ready to be formatted using a formatting tool provided by your operating system.

7 Specifications

This chapter provides specifications for your computer.

Computer specifications

This section provides specifications for your computer. When traveling with your computer, the computer dimensions and weights, as well as input power ratings and operating specifications, provide helpful information.

Table 7-1 Computer specifications

	Metric	U.S.
Dimensions		
Width	325.7 mm	12.82 in
Depth	218.5 mm	8.60 in
Height	17.9 mm	0.71 in
Weight		
	1.47 kg	3.24 lb
Temperature		
Operating	5°C to 35°C	41°F to 95°F
Nonoperating	-20°C to 60°C	-4°F to 140°F
Relative humidity (noncondensing)		
Operating	10% to 90%	
Nonoperating	5% to 95%	
Maximum altitude (unpressurized)		
Operating	-15 m to 3,048 m	-50 ft to 10,000 ft
Nonoperating	-15 m to 12,192 m	-50 ft to 40,000 ft
NOTE: Applicable product safety standards specify thermal limits for plastic surfaces. The device operates well within this range of temperatures.		

Display specifications

This section provides specifications for your display.

Table 7-2 Display specifications

	Metric	U.S.
Active diagonal size	29.5 cm	11.6 in
Resolution	1920 × 1080 (FHD) 1368 × 766 (HD)	

Table 7-2 Display specifications (continued)

	Metric	U.S.
Surface treatment	Antiglare	
Brightness	250 nits	
Viewing angle	UWVA	
Backlight	WLED	
Display panel interface	eDP	

8 Power cord set requirements

This chapter provides power cord requirements for countries and regions.

The wide-range input feature of the computer permits it to operate from any line voltage from 100 V ac to 120 V ac, or from 220 V ac to 240 V ac.

The three-conductor power cord set included with the computer meets the requirements for use in the country or region where the equipment is purchased.

Power cord sets for use in other countries or regions must meet the requirements of the country and region where the computer is used.

Requirements for all countries

These power cord requirements are applicable to all countries and regions.

- The length of the power cord set must be at least **1.0 m** (3.3 ft) and no more than **2.0 m** (6.5 ft).
- All power cord sets must be approved by an acceptable accredited agency responsible for evaluation in the country or region where the power cord set will be used.
- The power cord sets must have a minimum current capacity of 10 A and a nominal voltage rating of 125 V ac or 250 V ac, as required by the power system of each country or region.
- The appliance coupler must meet the mechanical configuration of an EN 60 320/IEC 320 Standard Sheet C13 connector for mating with the appliance inlet on the back of the computer.

Requirements for specific countries and regions

To determine power cord requirements for specific countries and regions, use this table.

Table 8-1 Power cord requirements for specific countries and regions

Country/region	Accredited agency	Applicable note number
Argentina	IRAM	1
Australia	SAA	1
Austria	OVE	1
Belgium	CEBEC	1
Brazil	ABNT	1
Canada	CSA	2
Chile	IMQ	1
Denmark	DEMKO	1
Finland	FIMKO	1
France	UTE	1
Germany	VDE	1

Table 8-1 Power cord requirements for specific countries and regions (continued)

Country/region	Accredited agency	Applicable note number
India	BIS	1
Israel	SII	1
Italy	IMQ	1
Japan	JIS	3
Netherlands	KEMA	1
New Zealand	SANZ	1
Norway	NEMKO	1
People's Republic of China	CCC	4
Saudi Arabia	SASO	7
Singapore	PSB	1
South Africa	SABS	1
South Korea	KTL	5
Sweden	SEMKO	1
Switzerland	SEV	1
Taiwan	BSMI	6
Thailand	TISI	1
United Kingdom	ASTA	1
United States	UL	2

1. The flexible cord must be Type H05VV-F, three-conductor, 0.75 mm² conductor size. Power cord set fittings (appliance coupler and wall plug) must bear the certification mark of the agency responsible for evaluation in the country or region where it will be used.
2. The flexible cord must be Type SVT/SJT or equivalent, No. 18 AWG, three-conductor. The wall plug must be a two-pole grounding type with a NEMA 5-15P (15 A, 125 V ac) or NEMA 6-15P (15 A, 250 V ac) configuration. CSA or C-UL mark. UL file number must be on each element.
3. The appliance coupler, flexible cord, and wall plug must bear a T mark and registration number in accordance with the Japanese Dentori Law. The flexible cord must be Type VCTF, three-conductor, 0.75 mm² or 1.25 mm² conductor size. The wall plug must be a two-pole grounding type with a Japanese Industrial Standard C8303 (7 A, 125 V ac) configuration.
4. The flexible cord must be Type RVV, three-conductor, 0.75 mm² conductor size. Power cord set fittings (appliance coupler and wall plug) must bear the CCC certification mark.
5. The flexible cord must be Type H05VV-F three-conductor, 0.75 mm² conductor size. KTL logo and individual approval number must be on each element. Approval number and logo must be printed on a flag label.
6. The flexible cord must be Type HVCTF three-conductor, 1.25 mm² conductor size. Power cord set fittings (appliance coupler, cable, and wall plug) must bear the BSMI certification mark.
7. For 127 V ac, the flexible cord must be Type SVT or SJT 3-conductor, 18 AWG, with plug NEMA 5-15P (15 A, 125 V ac), with UL and CSA or C-UL marks. For 240 V ac, the flexible cord must be Type H05VV-F three-conductor, 0.75 mm² or 1.00 mm² conductor size, with plug BS 1363/A with BSI or ASTA marks.

9 Recycling

When a nonrechargeable or rechargeable battery has reached the end of its useful life, do not dispose of the battery in general household waste. Follow the local laws and regulations in your area for battery disposal.

HP encourages customers to recycle used electronic hardware, HP original print cartridges, and rechargeable batteries. For more information about recycling programs, see the HP website at <http://www.hp.com/recycle>.

Index

- A**
 - AC adapter light 3, 4
 - AC adapters, spare part numbers 13
 - action 7
 - action keys
 - identifying 7
 - audio-in (microphone) jack, identifying 4
 - audio-out (headphone) jack, identifying 4
- B**
 - backing up 42
 - battery
 - light 3, 4
 - Bluetooth label 8
 - bottom cover
 - removal 23
 - spare part number 23
- C**
 - cables
 - spare part numbers 13
 - camera light, identifying 5
 - camera, identifying 5
 - caring for your computer 19
 - cautions
 - electrostatic discharge 15, 16
 - Chromebook Recovery Utility, installing 43
 - cleaning your computer 19
 - caring for wood veneer 21
 - disinfecting 20
 - HP Easy Clean 19
 - removing dirt and debris 19
 - components
 - display 5
 - keyboard area 6
 - left side 4
 - right side 3
 - computer major components 10
 - computer specifications 45
- D**
 - display
 - specifications 45
 - display assembly
 - subcomponents 11
- E**
 - electrostatic discharge (ESD) 15, 16
 - preventing damage 15, 16, 17
 - esc key, identifying 7
- G**
 - grounding methods 15, 16, 17
 - guidelines
 - packaging 15, 21
 - transporting 15, 21
 - workstation 15
- H**
 - hard drive
 - specifications 45
 - headphone (audio-out) jack 4
 - heat sink
 - removal 30
 - spare part numbers 30
- I**
 - illustrated parts catalog 10
 - internal microphones, identifying 5
- J**
 - jacks
 - audio-in (microphone) 4
 - audio-out (headphone) 4
- K**
 - keyboard
 - product description 2
 - keyboard with top cover
 - spare part numbers 40
 - keys 7
 - esc 7
 - power 7
- L**
 - labels
 - Bluetooth 8
 - regulatory 8
 - serial number 8
 - service 8
 - wireless certification 8
 - WLAN 8
 - lights
 - AC adapter and battery 3, 4
 - camera 5
- M**
 - memory card reader, identifying 4
 - microphone (audio-in) jack, identifying 4
- P**
 - packaging guidelines 15, 21
 - pointing device, product description 2
 - ports
 - product description 2
 - USB SuperSpeed port with HP Sleep and Charge 3
 - USB Type-C power connector and port 3, 4
 - power cord
 - requirements for all countries 47
 - requirements for specific countries and regions 47
 - set requirements 47
 - power cords, spare part numbers 13
 - power key, identifying 7
 - product description
 - keyboard 2
 - pointing device 2
 - ports 2
 - product name and number, computer 8

R

- recovery media
 - creating 43
 - erase 44
- recovery, performing 42
- regulatory information
 - regulatory label 8
 - wireless certification labels 8
- removal and replacement
 - procedures 23
- resetting 42

S

- Screw Kit, spare part number 13
- serial number, computer 8
- service labels, locating 8
- spare part country codes 40
- speaker
 - removal 27
 - spare part numbers 27
- speakers, identifying 6
- specifications
 - computer 45
 - display 45
 - hard drive 45
- static electricity 15, 16
- support information 21
- system board
 - removal 31
 - spare part numbers 31
- system recovery
 - Chrome operating system 43
 - Chromebook Recovery Utility 43
 - recovery media 43

T

- touchpad
 - removal 28
 - spare part numbers 28
- touchpad zone, identifying 6
- transporting guidelines 15, 21
- traveling with the computer 8

U

- USB board
 - removal 29
 - spare part numbers 29
- USB SuperSpeed port with HP Sleep and Charge, identifying 3
- USB Type-C power connector and port, identifying 3, 4

W

- wireless certification label 8
- WLAN antennas, identifying 5
- WLAN device 8
- WLAN label 8
- WLAN module
 - removal 26
 - spare part numbers 26
- workstation guidelines 15